

# Technical Information

## Raman Rxn2



## Table of Contents

### **Function and system design ..... 3**

Analyzer technology ..... 3  
 Front panel ..... 4  
 Rear panel ..... 5  
 Interior of the Raman Rxn2 ..... 5  
 Port connections ..... 6

### **Software ..... 7**

Raman RunTime ..... 7  
 User privilege levels ..... 8  
 Software requirements ..... 8

### **Installation ..... 9**

Mounting location ..... 9

Ventilation ..... 9  
 Air filter ..... 9

### **Specifications ..... 10**

Dimensions ..... 10  
 Analyzers ..... 11  
 Laser ..... 12  
 Probes ..... 12  
 Sound levels ..... 12  
 Network configuration ..... 12

### **Certificates and approvals ..... 13**

Hazard area rating ..... 13  
 Hazard area certification ..... 13  
 Hazard area drawing ..... 14

---

## Function and system design

---

### Analyzer technology

The Raman Rxn2 Raman analyzer is a for-purpose embedded system with built-in Raman RunTime control software. Raman spectroscopy provides the chemical specificity of mid-IR spectroscopy and the sampling simplicity of a near-IR analyzer. By operating in the visible spectral region, Raman spectroscopy allows vibrational spectra to be collected *in situ*, using fiber-coupled probeheads, without sample purging, and without the use of exotic sampling devices.

The Raman Rxn2 suite of analyzers are based on advanced and innovative technologies that provide distinct advantages over traditional instrumentation. The HoloPlex advantage, standard in all Raman Rxn2 analyzers, yields both full spectral coverage and high spectral resolution simultaneously for improved qualitative and quantitative analysis. Analysis is fast because the entire Raman spectrum is measured simultaneously, which translates into real-time data collection for reaction analysis and monitoring.

All Raman Rxn2 analyzers employ a unique self-monitoring system to ensure the validity of each analysis. The analyzer is capable of two-point self-calibration in extreme environments and utilizes self-diagnostics and spectral correction methods when system calibration is unnecessary. The analyzer's precision is essential for robust chemometric analyses and calibration transfer between instruments.

The Raman Rxn2 suite of analyzers allow for remote fiber-optic connections to probe sampling points for installation flexibility.

The Raman Rxn2 can be configured as a single channel, four channel, or Hybrid Raman analyzer. All are designed for use with the Endress+Hauser Raman fiber optic probe line.

**Front panel**

The front panel of the Raman Rxn2 analyzer is shown below:

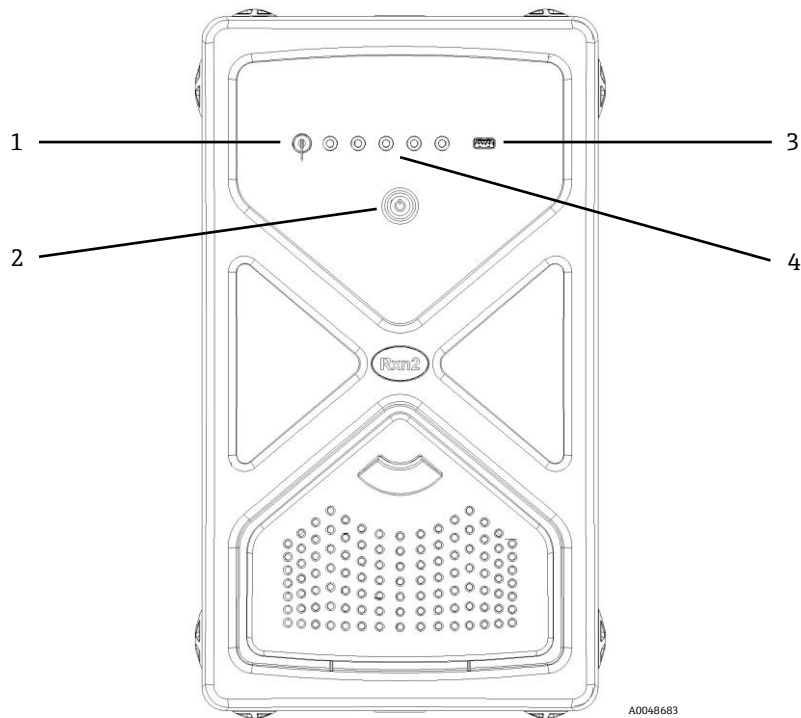

Figure 1. Front panel of a Raman Rxn2 four channel analyzer

#	Name	Description
1	Laser Key Switch	The laser key switch turns the laser on and off. The <b>Red</b> LED indicator adjacent to the laser key switch indicates the laser power status. To activate turn the key to the <b>ON</b> position.
2	Main Power Switch	The main power switch turns the instrument on and off, which includes the laser regardless of the position of the laser key switch. The <b>Power</b> push button incorporates a <b>Blue</b> LED in the shape of a power symbol, which indicates the system power status. The <b>Power</b> push button will communicate error conditions using blink codes when embedded software is not able to communicate them. To turn the instrument on, press and release the <b>Power</b> button once. To turn a responsive instrument off, shut down using Raman RunTime. If the instrument is unresponsive, it may be powered down using a long 10 second press and hold of the <b>Power</b> button.
3	USB 3.0 Port	The USB 3.0 port is intended to obtain diagnostic exports from the instrument using a USB flash drive.
4	Probe Connection Status Indicators	The bank of <b>Yellow</b> LED indicators between the laser key and USB 3.0 port indicate the physical connection status of the probes. While the Raman Rxn2 four channel analyzer front panel has four LED indicators, the front panel of the Raman Rxn2 Hybrid analyzer has only two LED indicators, and the front panel of the Raman Rxn2 single channel analyzer has only one LED indicator.

Table 1. Front panel of Raman Rxn2

**Rear panel**

The rear panel of the Raman Rxn2 analyzer is shown below:

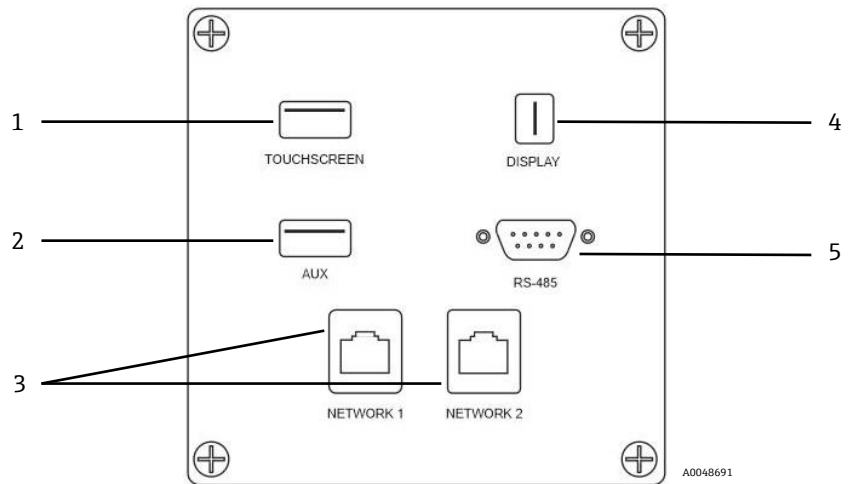

Figure 2. Rear external circuit input/output panel of a Raman Rxn embedded analyzer

#	Name	Description	
1	TOUCHSCREEN	USB 2.0 Port	Input from touchscreen.
2	AUX	USB 2.0 Port	Reserved for future use.
3	NETWORK 1 and NETWORK 2	Two 1GB TCP/IP Ethernet Ports	Ethernet connection for OPC and Modbus communication and automation.
4	DISPLAY	Mini DisplayPort	Video connection for optional touchscreen.
5	RS-485	DB9 connector for 2-wire, half-duplex Modbus RTU interface. Pin 2 is Data+, Pin 3 is Data -, and Pin 5 is ground.	Modbus RTU interface connection.

Table 2. Raman Rxn2 ports

**Interior of the Raman Rxn2**

The interior of the Raman Rxn2 with the cover removed is shown below. The internal components are common among all configurations.

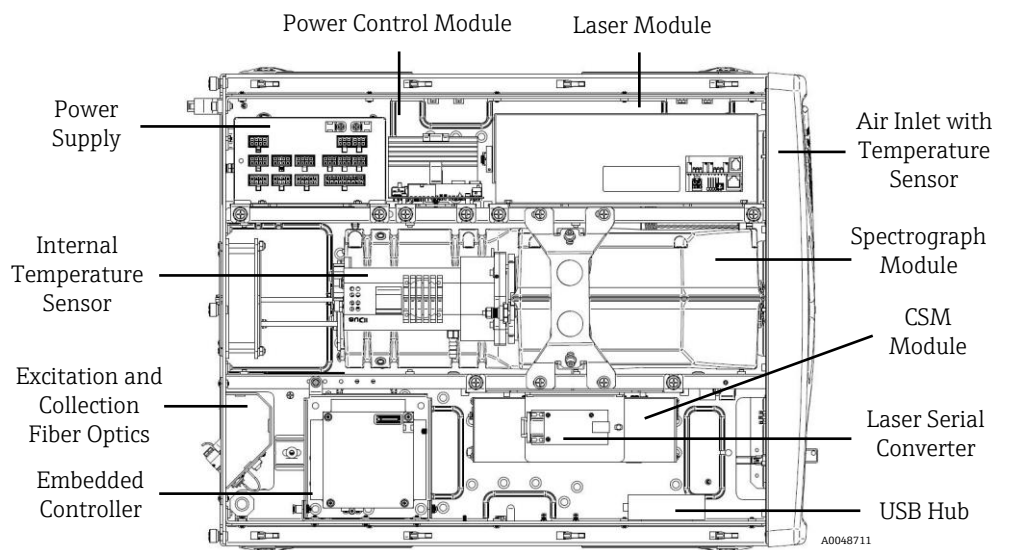

Figure 3. The interior of the Raman Rxn2 analyzer

**Port connections**

The port connections for the Raman Rxn2 analyzer are shown below:

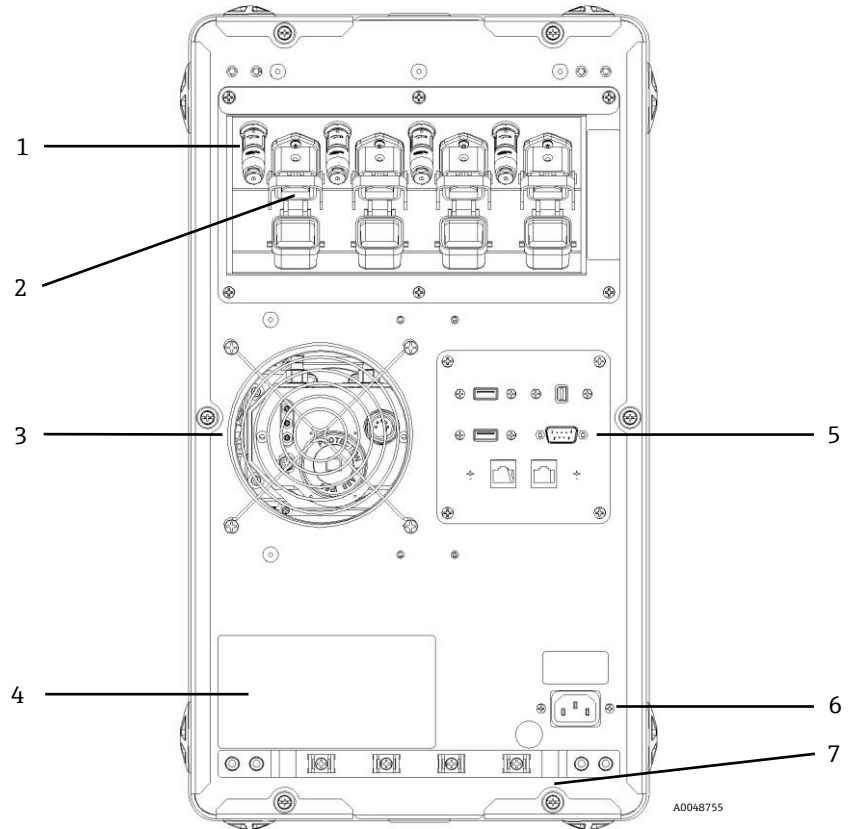

Figure 4. Rear panel of Raman Rxn2

#	Name	Description
1	Remote Interlock Connectors	Safety feature. To interrupt the laser, remove the black plug.
2	EO Fiber Connector	Provides fiber optic laser radiation output, fiber optic Raman collection and electrical laser interlock loop for each instrument channel. The electrical laser interlock loop is intrinsically safe and is governed by Endress+Hauser drawing 4002396. Match 3 prongs on probe to 3 plugs on EO. Pull latch down to secure probe in place. Laser radiation may NOT exit a channel whose EO fiber connector is removed because removing the EO connector also interrupts the laser interlock loop for that channel.
3	Air Exhaust	Air exhaust fan and outlet.
4	CDRH Product Label	Product information about the Raman Rxn2 analyzer.
5	Analyzer Ports	Touchscreen USB Port, USB Port, Ethernet Ports, RS-485 Serial Port, and Touchscreen Video Port.
6	AC Inlet 100-240 VAC 50/60 Hz	Power socket outlet that AC power to the base unit. Ground pin on this connector serves as the Protective Conductor Terminal.
7	Strain Relief	EO fiber cable strain relief mounting location.

Table 3. Port connection

## Software

### Raman RunTime

Raman RunTime embedded software is the control platform for its suite of Raman Rxn analyzers. Raman RunTime software is intended for easy integration with standard multivariate analysis and automation platforms to enable a real-time, *in situ* process monitoring and control solution. Raman RunTime presents an OPC and Modbus interface, which provides clients with analyzer data as well as analyzer control functions. Raman RunTime is fully embedded into Raman Rxn analyzers.

The main view of Raman RunTime displays four quadrants for four channel analyzers, one for each probe and a status bar (bottom) for a quick view of warnings and acquisition status. Single channel analyzers display only one main channel/probe window, while Hybrid analyzers display two channel/probe windows, one for the Rxn-20 probe channel and one for the non-Rxn-20 probe ALT. Batch details are accessed and edited from each corresponding quadrant/probe window. To switch back and forth between the main view and batch detail views, click the Title Bar for each probe/quadrant. Views of current spectrum vs. process values (model results) can also be easily swapped with by clicking on the Quadrant/Probe window display. Additional features, such as system settings, calibration and diagnostics, are found under the Options section on the lower left corner of the screen.



Figure 5. Raman RunTime's main view in a Raman Rxn four channel analyzer

A0048754

**User privilege levels**

The Raman Runtime user levels are described below:

User Level	Action
User	<ul style="list-style-type: none"> <li>▪ Change subject (channel) display name</li> <li>▪ View summary and detail of active batch acquisitions</li> <li>▪ View calibration of information</li> <li>▪ View diagnostics</li> <li>▪ Perform exports (Basic, Diagnostic, Full)</li> </ul>
Operator	User level actions plus: <ul style="list-style-type: none"> <li>▪ View active batch acquisitions</li> <li>▪ Perform calibration and view calibrations information</li> <li>▪ Perform verification and view verification results</li> <li>▪ Start/stop batch acquisitions</li> <li>▪ Focus</li> <li>▪ Snapshot</li> <li>▪ Ad hoc analysis</li> <li>▪ Change system display name</li> <li>▪ Configure date and time</li> <li>▪ Restart</li> </ul>
Admin	No Restrictions Operator level restrictions plus: <ul style="list-style-type: none"> <li>▪ Add/remove models</li> <li>▪ Configure models (display name, enable/disable components &amp; properties)</li> <li>▪ Configure network</li> <li>▪ Configure Open platform communications (OPC)</li> <li>▪ Change security settings &amp; manage users</li> <li>▪ Apply embedded software updates</li> </ul>

*Table 4. User privileges*

**Software requirements**

The client system software requirements are described below:

- Silverlight 5.0 or greater (for remote access)
- OPC UA client software (for OPC interface)
- OPC Classic client software (for OPC interface)
- Modbus client software (for Modbus interface)



## Installation

### Mounting location

The analyzer can be located on a level surface such as a laboratory benchtop or an equipment cart. In addition, the location selected should be:

- Free of moisture, dust, and corrosive vapors
- Isolated from excess vibrations

### Ventilation

The location selected should allow for adequate ventilation to both the front and rear of the base unit. A space of not less than 6 inches (155 mm) must be provided in both the front and rear of the base unit for proper inlet and outlet air movement.

### Air filter

The Raman Rxn2 incorporates a tacked polyester spun air filter element to reduce dust intake into the base unit. The air filter is accessed by a magnetically secured access panel on the front of the instrument (4). The air filter should be cleaned with compressed air once every month or if the embedded software is reporting an internal over-temperature error (if ambient temperature is within specification). In extremely dusty conditions, the air filter should be cleaned more often. The air filter has a **Blue** tacky side which should be oriented toward the outside of the base unit.

If a replacement air filter is needed, refer to our website (<https://endress.com/contact>) for the list of local sales channels in your area.

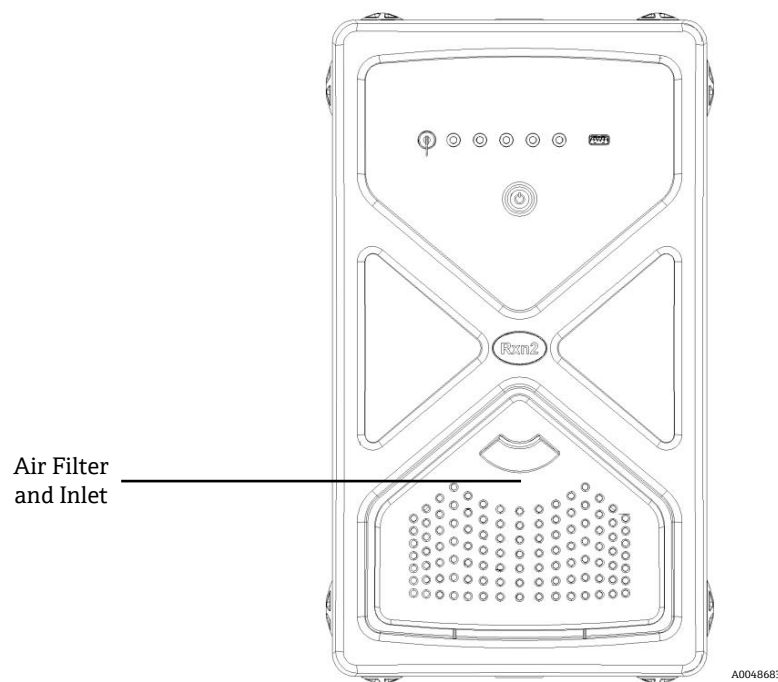

Figure 6. Filter access

## Specifications

### Dimensions

The width, depth, and length of the Raman Rxn2 analyzer are shown below:

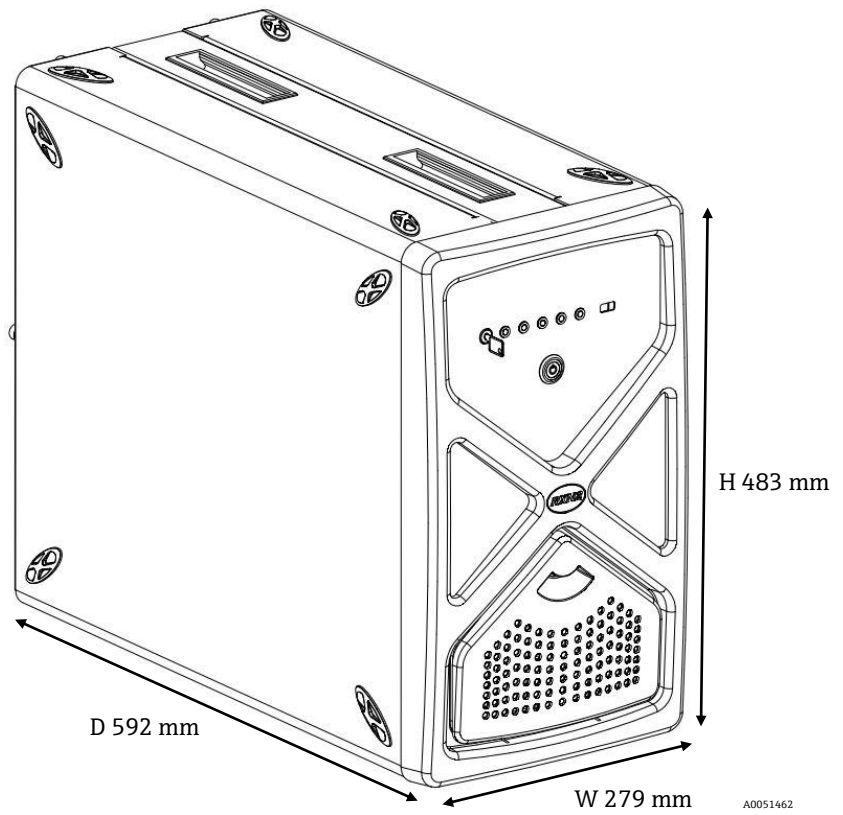

Figure 7. Raman Rxn2 dimensions

Name	Description
Height	483 mm (19 in.)
Width	279 mm (11 in.)
Length	592 mm (23.3 in.)

Table 5. Raman Rxn2 dimensions

## Analyzers

The specifications for the three types of Raman Rxn2 analyzers are listed below:

Item	Raman Rxn2 Starter	Raman Rxn2	Raman Rxn2 Hybrid
Laser Wavelength	785 nm	532 nm 785 nm 1000 nm	785 nm
Spectral Coverage	300-3300 $\text{cm}^{-1}$ (785 nm)	150-4350 $\text{cm}^{-1}$ (532 nm) 150-3425 $\text{cm}^{-1}$ (785 nm) 200-2400 $\text{cm}^{-1}$ (1000 nm)	175-1890 $\text{cm}^{-1}$ (785 nm)
Spectral Resolution	10 $\text{cm}^{-1}$ average	5 $\text{cm}^{-1}$ (532 nm) 4 $\text{cm}^{-1}$ (785 nm) 5 $\text{cm}^{-1}$ (1000 nm) average	4 $\text{cm}^{-1}$ (785 nm) average
Temperature / % Relativity Humidity	<i>Ops Temp:</i> 15 °C to 30 °C (59 °F to 86 °F) <i>Stg Temp:</i> -15 °C to 50 °C (5 °F to 122 °F) <i>Relative Humidity:</i> 20 % to 80 %, non-condensing	<i>Ops Temp:</i> 15 °C to 30 °C (59 °F to 86 °F) <i>Stg Temp:</i> -15 °C to 50 °C (5 °F to 122 °F) <i>Relative Humidity:</i> 20 % to 80 %, non-condensing	<i>Ops Temp:</i> 15 °C to 30 °C (59 °F to 86 °F) <i>Stg Temp:</i> -15 °C to 50 °C (5 °F to 122 °F) <i>Relative Humidity:</i> 20 % to 80 %, non-condensing
Input Voltage	100-240 V 50-60 Hz ±10 %	100-240 V 50-60 Hz ±10 %	100-240 V 50-60 Hz ±10 %
Power Consumption	400 W (max) 250 W (typical start-up) 120 W (typical running)	400 W (max) 250 W (typical start-up) 120 W (typical running)	400 W (max) 250 W (typical start-up) 120 W (typical running)
Warm-up Time	120 minutes	120 minutes	120 minutes
Unit Dimensions	<i>Benchtop Model:</i> 279 x 483 x 592 mm <i>Cart Model:</i> 685 x 1022 (to tabletop) x 753 mm	<i>Benchtop Model:</i> 279 x 483 x 592 mm <i>Cart Model:</i> 685 x 1022 (to tabletop) x 753 mm	<i>Benchtop Model:</i> 279 x 483 x 592 mm <i>Cart Model:</i> 685 x 1022 (to tabletop) x 753 mm
Weight	<i>Base Model:</i> 32 kg <i>Cart Model:</i> 93 kg	<i>Base Model:</i> 32 kg <i>Cart Model:</i> 93 kg	<i>Base Model:</i> 32 kg <i>Cart Model:</i> 93 kg
Sampling Probe Compatibility	Rxn-10 (with optics)	Rxn-10 (with optics), Rxn-30, Rxn-40, Rxn-41, Rxn-45, and Rxn-46	Rxn-20 (with optics) and one alternate non-Rxn-20 Endress+Hauser Raman probe
Hazardous Area Certifications	ATEX, North American, IECEx	ATEX, North American, IECEx	ATEX, North American, IECEx
Connection Interface	OPC, Modbus (contact Endress+Hauser for other options)	OPC, Modbus (contact Endress+Hauser for other options)	OPC, Modbus (contact Endress+Hauser for other options)
Installation Options	Benchtop (standard) or mobile wheeled cart	Benchtop (standard) or mobile wheeled cart	Benchtop (standard) or mobile wheeled cart

Table 6. Analyzer specifications

**Laser**

The specifications for the laser are listed below:

Item	Description
<b>532 nm</b> Excitation wavelength Maximum power output Warranty	532 nm 120 mW unlimited hours for 1 year
<b>785 nm</b> Excitation wavelength Maximum power output Warranty	785 nm 400 mW unlimited hours for 1 year
<b>1000 nm</b> Excitation wavelength Maximum power output Warranty	993 nm 400 mW unlimited hours for 1 year

Table 7. Laser

**Probes**

The specifications for the probes are listed below:

Item	Description
Raman Rxn2 (single channel, four channel, and Starter)	Compatible with: Rxn-10 probehead equipped with immersion or non-contact optics Endress+Hauser gas and liquid phase Raman probe Endress+Hauser bioprocessing Raman probes
Raman Rxn2 Hybrid	Compatible with: Rxn-20 probe and One other ALT probe including: Rxn-10 probehead equipped with immersion or non-contact optics Endress+Hauser gas and liquid phase Raman probe Endress+Hauser bioprocessing Raman probes

Table 8. Probes

**Sound levels**

The specifications for the sound levels are listed below:

Analyzer / Accessory	Sound Level from Operator's Position
Raman Rxn2	58.9 dB

Table 9. Sound levels

**Network configuration**

The table below summarizes the ports relevant to specific Raman Runtime features. Ports for OPC Classic are assigned dynamically in the indicated range; fixed-port behavior is only available for OPC UA. It's only necessary to open firewall ports for the features intended to use. Ports in bold should be regarded as mandatory for the associated protocol; other ports are recommended for full functionality (e.g. discovery services).

Protocol	Ports
OPC UA	TCP 4840, 4843, 52601, and <b>62886</b>
OPC Classic	TCP <b>135</b> and <b>49152-65535</b>
Modbus	TCP <b>502</b>
File Sharing	TCP <b>139</b> and <b>445</b>
Remote Access	TCP <b>943</b> , <b>3593</b> , <b>4525</b> , and 5674; User Datagram Protocol (UDP) 3702

Table 10. Raman RunTime network configuration

## Certificates and approvals

### Hazard area rating

The hazard area rating details are listed below:

Item	Description
Rxn-10 Probe	None
Rxn-20 series probes can be classified to:	<p><b>ATEX</b>  <math>\langle Ex \rangle</math> II 2/1 G Ex ia op is IIA or IIB or IIB+H2 or IIC T4 or T3 or T6 Ga  <math>-20\text{ }^{\circ}\text{C}</math> (68 °F) <math>\leq</math> TA <math>\leq</math> 60 °C (140 °F)</p> <p><b>IECEX</b>            IECEX ITS 14.0015X</p> <p><b>North American</b>            Ex ia op is IIA or IIB or IIB + H2 or IIC T3 or T4 or T6 Ga            Class I, Division 1, Groups A, B, C, D T3/T4/T6            Class I, Zone 0 AEx ia op is IIA or IIB or IIB + H2 or IIC T3 or T4 or T6 Ga</p>
Rxn-30 series probes can be classified to:	<p><b>ATEX</b>  <math>\langle Ex \rangle</math> II 2/1 G Ex ia op is IIA or IIB or IIB+H2 or IIC T3 or T4 or T6 Ga  <math>-20\text{ }^{\circ}\text{C}</math> (68 °F) <math>\leq</math> TA <math>\leq</math> 60 °C (140 °F)</p> <p><b>IECEX</b>            IECEX ITS 14.0015X</p> <p><b>North American</b>            Ex ia IIB+H2 T4            Class I Zone 0 AEx ia IIB+H2 T4            Class I Division 1 Groups B, C, &amp; D T4</p>
Rxn-40 and Rxn-41 series probes can be classified to:	<p><b>ATEX</b>  <math>\langle Ex \rangle</math> II 2/1 G Ex ia op is IIA or IIB or IIB+H2 or IIC T3 or T4 or T6 Ga  <math>-20\text{ }^{\circ}\text{C}</math> (68 °F) <math>\leq</math> TA <math>\leq</math> 60 °C (140 °F)</p> <p><b>IECEX</b>            IECEX ITS 14.0015X</p> <p><b>North American</b>            Ex ia IIC T4            Class I Zone 0 AEx ia IIC T4            Class I Division 1 Groups A, B, C, &amp; D T4</p>
Rxn-45 Probe	None

Table 11. Hazardous area rating

### Hazard area certification

The hazard area certification details are listed below:

Item	Description
Certification – Base Unit (fiber optic and interlock outputs only)	<p><b>ATEX</b>  <math>\langle Ex \rangle</math> II (2)(1) G Ex [ia Ga]            [op sh Gb] IIC</p> <p><b>IECEX</b>            Ex [ia Ga] [op sh Gb] IIC            IECEX ITS 20.0050X</p> <p><b>North American</b>            Intrinsically Safe output for probe and sensors used in Class I, Division 1, Groups A, B, C, and D.            Ambient Temperature Range: 5°C (41 °F) <math>\leq</math> Tamb <math>\leq</math> 35°C (95 °F)</p>

Table 12. Hazardous area certification

Hazard area drawing

The hazard area installation drawing is shown below:

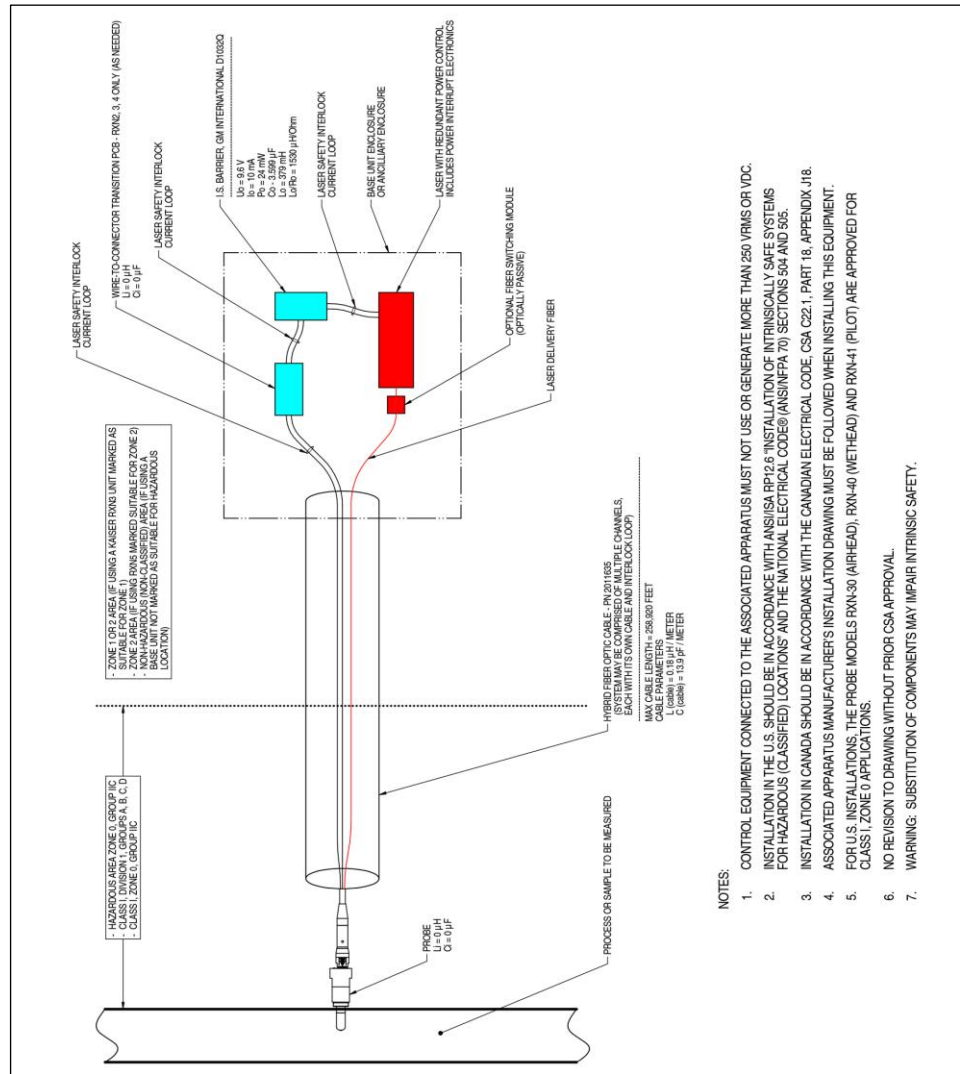

Figure 8. Hazardous area certification

A0049010

[www.addresses.endress.com](http://www.addresses.endress.com)

---