

Technical Information

T53, T54 and T55

Explosion proof thermocouple assemblies in thermowells with spring loaded insert and enclosure for process industry



Application

Magnesium Oxide insulated thermocouples, commonly referred to as MgO thermocouples, are used in many process and laboratory applications. They have many desirable characteristics making thermocouples a good choice for general and special purpose applications.

The sensor assemblies can be used in process industries such as:
Chemicals, Petrochemical, Refineries, Offshore Platforms

Head transmitter

All Endress+Hauser transmitters are available with enhanced accuracy and reliability compared to directly wired sensors. Easy customizing by choosing one of the following outputs and communication protocols:

- Analog output 4 to 20 mA
- HART®, PROFIBUS® PA, FOUNDATION Fieldbus™
- Bluetooth® connectivity (optional)

Field transmitter

Temperature field transmitters with HART® or FOUNDATION Fieldbus™ protocol for highest reliability in harsh industrial environments. Backlit display with large measured value, bargraph and fault condition indication for ease of reading.

Your benefits

- CSA C/US XP and FM/CSA XP Class I, Div. 1 approved temperature assemblies for maximum safety.
- One source shopping for temperature measurement solutions. World class transmitter with integrated sensor offering for heavy process industry applications.
- Improved galvanic isolation on most devices (2 kV)
- Simplified model structure: Competitively priced, offers great value. Easy to order and reorder. A single model number includes sensor, thermowell and transmitter assembly for a complete point solution.
- All iTEMP transmitters provide long-term stability $\leq 0.05\%$ per year

Function and system design

Measuring principle

Thermocouples (TC)

Thermocouples are comparatively simple, robust temperature sensors which use the Seebeck effect for temperature measurement: if two electrical conductors made of different materials are connected at a point, a weak electrical voltage can be measured between the two open conductor ends if the conductors are subjected to a thermal gradient. This voltage is called thermoelectric voltage or electromotive force (emf.). Its magnitude depends on the type of conducting materials and the temperature difference between the "measuring point" (the junction of the two conductors) and the "cold junction" (the open conductor ends). Accordingly, thermocouples primarily only measure differences in temperature. The absolute temperature at the measuring point can be determined from these if the associated temperature at the cold junction is known or is measured separately and compensated for. The material combinations and associated thermoelectric voltage/temperature characteristics of the most common types of thermocouple are standardized in the IEC 60584 and ASTM E230/ANSI MC96.1 standards.

Measuring system

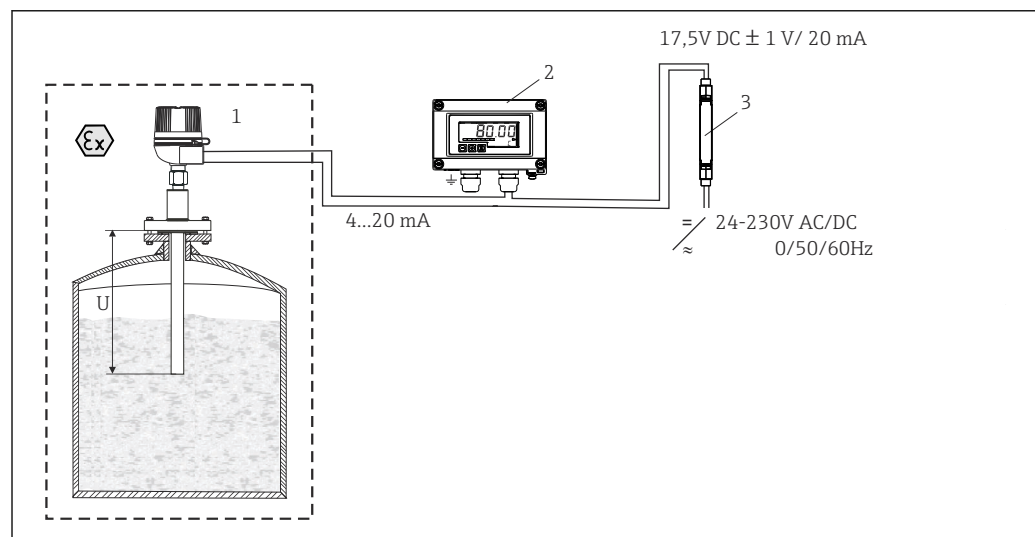

A0024883

1 Application example

- 1 Mounted thermometer with head transmitter installed.
- 2 RIA15 process display - The display unit records the analog measuring signal from the head transmitter and shows this on the display. The LC display shows the current measured value in digital form and as a bar graph indicating a limit value violation. The process display unit is integrated in the 4 to 20 mA or HART® loop and is powered directly from the current loop. Optionally up to four of a sensor's HART® process variables can be displayed. More information on this can be found in the Technical Information.
- 3 Active barrier RN42 - The device (17.5 V_{DC}, 20 mA) active barrier has a galvanic isolated output for supplying voltage to loop powered transmitters. The universal power supply works with an input supply voltage of 24 to 230 V AC/DC, 0/50/60 Hz, which means that it can be used in all international power grids. More information on this can be found in the Technical Information.

Input

Measured variable Temperature (temperature-linear transmission behavior)

Measurement range

Upper temperature limits for various sheath diameters °C (°F)					
Sheath O.D.	Type T	Type J	Type E	Type K	Type N
∅ ¼ in	370 °C (700 °F)	370 °C (700 °F)	820 °C (1510 °F)	1150 °C (2100 °F)	
Maximum element temperature range limits	-270 to +400 °C (-454 to +752 °F)	-210 to +1200 °C (-346 to +2192 °F)	-270 to +1000 °C (-454 to +1832 °F)	-270 to +1372 °C (-454 to +2500 °F)	-270 to +1300 °C (-454 to +2372 °F)



These values are valid for single and duplex thermocouples. The temperature limits given are intended only as a guide to the user and should not be taken as absolute values or as guarantees of satisfactory life or performance. These types and sizes are sometimes used at temperatures above the given limits, but usually at the expense of stability or life or both. In other instances, it may be necessary to reduce the above limits in order to achieve adequate service.

Thermocouples with 316 SS sheath and assemblies with 316 SS thermowells are rated for a maximum temperature of 927 °C (1700 °F).

Output

Output signal

Generally, the measured value can be transmitted in one of two ways:

- Directly-wired sensors - sensor measured values forwarded without a transmitter.
- Via all common protocols by selecting an appropriate Endress+Hauser iTEMP temperature transmitter. All the transmitters listed below are mounted directly in the terminal head or as field transmitter and wired with the sensory mechanism.

Family of temperature transmitters

Thermometers fitted with iTEMP transmitters are an installation-ready complete solution to improve temperature measurement by significantly increasing accuracy and reliability, when compared to direct wired sensors, as well as reducing both wiring and maintenance costs.

4 to 20 mA head transmitters

They offer a high degree of flexibility, thereby supporting universal application with low inventory storage. The iTEMP transmitters can be configured quickly and easily at a PC. Endress+Hauser offers free configuration software which can be downloaded from the Endress+Hauser Website. More information can be found in the Technical Information.

HART® head transmitters

The transmitter is a 2-wire device with one or two measuring inputs and one analog output. The device not only transfers converted signals from resistance thermometers and thermocouples, it also transfers resistance and voltage signals using HART® communication. Swift and easy operation, visualization and maintenance using universal device configuration tools like FieldCare, DeviceCare or FieldCommunicator 375/475. Integrated Bluetooth® interface for the wireless display of measured values and configuration via E+H SmartBlue (app), optional. For more information, see the Technical Information.

PROFIBUS® PA head transmitters

Universally programmable head transmitter with PROFIBUS® PA communication. Conversion of various input signals into digital output signals. High accuracy over the complete ambient temperature range. The configuration of PROFIBUS PA functions and of device-specific parameters is performed via fieldbus communication. For more information, see the Technical Information.

FOUNDATION Fieldbus™ head transmitters

Universally programmable head transmitter with FOUNDATION Fieldbus™ communication. Conversion of various input signals into digital output signals. High accuracy over the complete ambient temperature range. All transmitters are released for use in all important process control

systems. The integration tests are performed in Endress+Hauser's "System World". For more information, see the Technical Information.

Advantages of the iTEMP transmitters:

- Dual or single sensor input (optionally for certain transmitters)
- Pluggable display (optionally for certain transmitters)
- Unsurpassed reliability, accuracy and long-term stability in critical processes
- Mathematical functions
- Monitoring of the thermometer drift, sensor backup functionality, sensor diagnostic functions
- Sensor-transmitter matching for dual sensor input transmitters, based on Callendar-Van-Dusen-coefficients (CvD).

Field transmitter

Field transmitter with HART®, FOUNDATION Fieldbus™ or PROFIBUS® PA communication and backlit display. Can be read easily from a distance, in sunlight and at night. Large measurement value, bargraph and fault indication displayed. Benefits are: dual sensor input, highest reliability in harsh industrial environments, mathematic functions, thermometer drift monitoring and sensor back-up functionality, corrosion detection.

Galvanic isolation

Galvanic isolation of Endress+Hauser iTEMP transmitters

Transmitter type	Sensor
TMT162 HART® Field transmitter	U = 2 kV AC
TMT71	
TMT72 HART®	
TMT82 HART®	
TMT84 PA	
TMT85 FF	
TMT142B	

i In applications where fast response time is needed, grounded thermocouples are recommended. This thermocouple design may cause a ground loop. This can be avoided by using iTEMP transmitters with high galvanic isolation

Power supply

Terminal assignments

Type of sensor connection

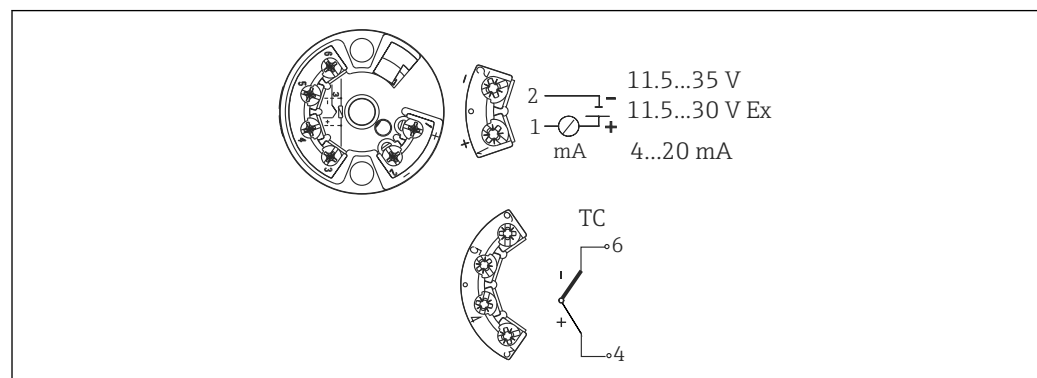

2 Head mounted transmitter TMT18x (single input)

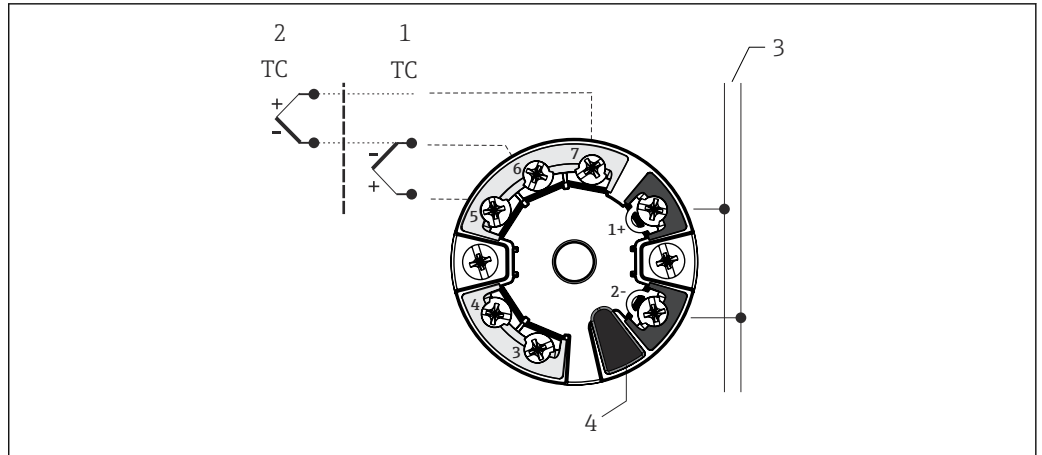

A0045474

3 Head mounted transmitter TMT8x (dual input)

- 1 Sensor input 2
- 2 Sensor input 1
- 3 Bus connection and supply voltage
- 4 Display connection

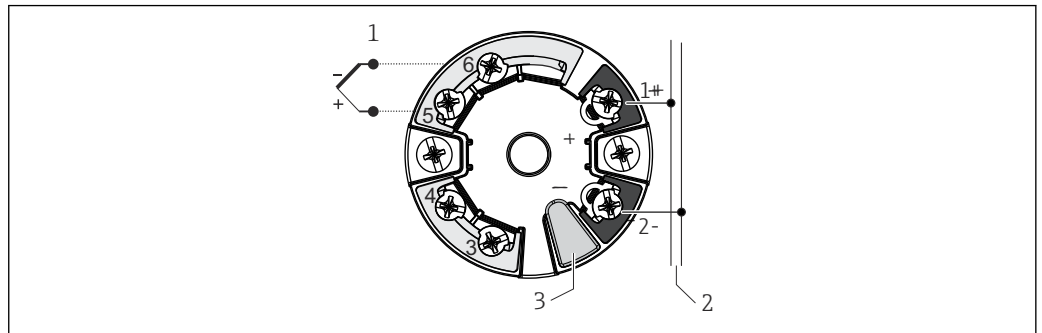

A0045353

4 Head mounted transmitter TMT7x (single input)

- 1 Sensor input
- 2 Bus connection and supply voltage
- 3 Display connection and CDI interface

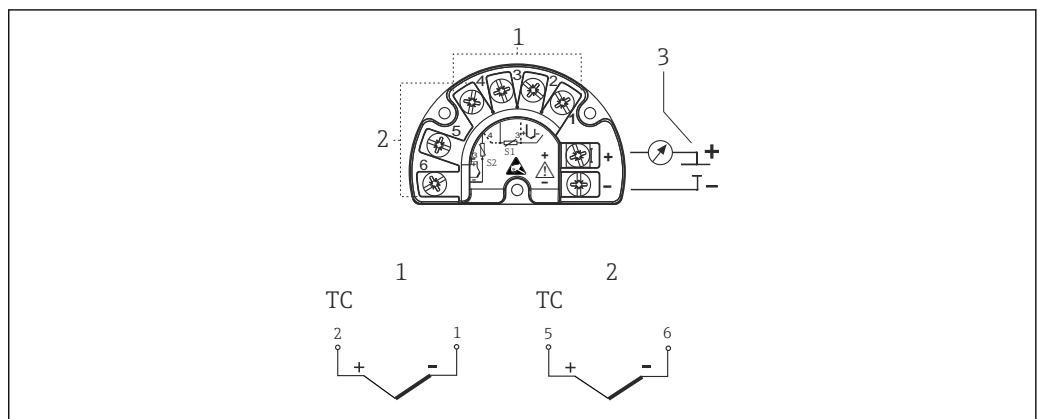

A0045636

5 Field mounted transmitter TMT162 (dual Input) or TMT142B (single Input)

- 1 Sensor 1
- 2 Sensor 2 (not TMT142B)
- 3 Power supply field transmitter and analog output 4 to 20 mA or bus connection

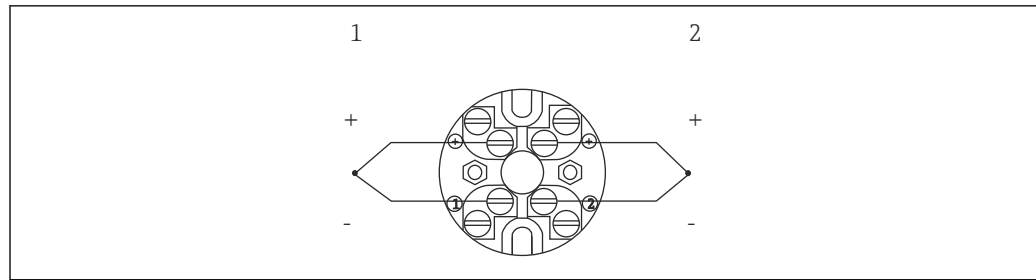

A0045637

6 Terminal block mounted

- 1 Sensor 1
- 2 Sensor 2

i The blocks and transmitters are shown as they sit inside the heads in reference to the conduit opening.

Integrated overvoltage protection

The integrated overvoltage protection module can be ordered as an optional extra ¹⁾. The module protects the electronics from damage from overvoltage. Overvoltage occurring in signal cables (e.g. 4 to 20 mA, communication lines (fieldbus systems) and power supply is diverted to ground. The functionality of the transmitter is not affected as no problematic voltage drop occurs.

Connection data:

Maximum continuous voltage (rated voltage)	$U_C = 42 V_{DC}$
Nominal current	$I = 0.5 A$ at $T_{amb.} = 80^\circ C$ (176 °F)
Surge current resistance <ul style="list-style-type: none"> ▪ Lightning surge current D1 (10/350 μs) ▪ Nominal discharge current C1/C2 (8/20 μs) 	<ul style="list-style-type: none"> ▪ $I_{imp} = 1 kA$ (per wire) ▪ $I_n = 5 kA$ (per wire) ▪ $I_n = 10 kA$ (total)
Temperature range	-40 to $+80^\circ C$ (-40 to $+176^\circ F$)
Series resistance per wire	1.8Ω , tolerance $\pm 5\%$

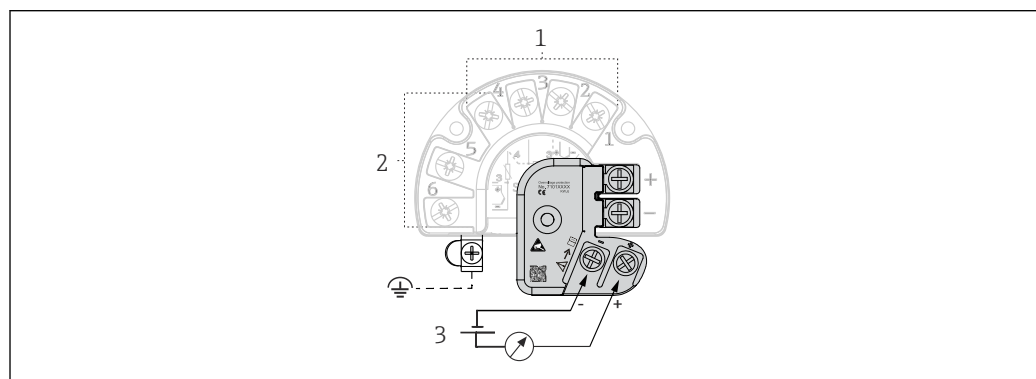

A0045614

7 Electrical connection of the overvoltage protection

- 1 Sensor 1
- 2 Sensor 2
- 3 Bus connection and supply voltage

Grounding

The device must be connected to the potential equalization. The connection between the housing and the local ground must have a minimum cross-section of 4 mm^2 (13 AWG). All ground connections must be secured tightly.

1) Available for the field transmitter with HART® 7 specification

Wire specifications

Thermocouple grade, TFE insulated 20AWG, 7 strands with stripped ends

Electrical connection
Flying leads, standard 139.7 mm (5.5 in) for wiring in connection head, head mounted transmitter or terminal block mounted, and for wiring with TMT162 or TMT142 assemblies

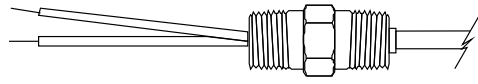
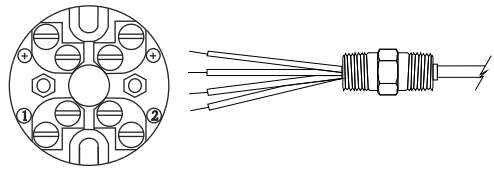
Design of leads	
Flying leads 139.7 mm (5.5 in) with stripped ends	 <p style="text-align: right; font-size: small;">A0027297</p>
Connection with terminal block (4 pole) with stripped ends	 <p style="text-align: right; font-size: small;">A0027298</p>

Thermocouple color codes according to ASTM E-230

T.C. Type	POS NEG	Material	MAGNETIC		Insulation	
			YES	NO	Single conductor	Overall T.C. wire
E	EP (+)	Nickel - 10% chromium		X	Purple	Brown
	EN (-)	Copper - 45% nickel (constantan)		X	Red	
J	JP (+)	Iron	X		White	Brown
	JN (-)	Copper - 45% nickel (constantan)		X	Red	
K	KP (+)	Nickel - 10% chromium		X	Yellow	Brown
	KN (-)	Nickel - 5% (aluminum, silicon) ¹⁾	X		Red	
T	TP (+)	Copper		X	Blue	Brown
	TN (-)	Copper - 45% nickel (constantan)		X	Red	
N	NP (+)	Nickel - 14% chromium - 1.5% silicon		X	Orange	Brown
	NN (-)	Nickel - 4.5% silicon - 0.1% magnesium		X	Red	

1) Silicon, or aluminum and silicon may be present in combination with other elements.

Performance characteristics

Reference conditions

These data are relevant for determining the accuracy of the temperature transmitters used. More information on this can be found in the Technical Information of the iTEMP temperature transmitters.

Response time

63% response time per ASTM E839

Thermocouple assembly T55 without thermowell

Junction style	Thermocouple insert $\varnothing\frac{1}{4}$ "
Ungrounded	2.9 s

 Response time for the sensor assembly without transmitter.

Response time examples for thermocouple assemblies with thermowell T53 and T54

Construction	Stepped thermowell	Tapered thermowell	3/4" straight thermowell
Time	15 s	20 s	25 s

 Response times for thermocouple assemblies with thermowell are provided for general design guidance without transmitter.

When the temperature of a process media changes, the output signal of a Thermocouple assembly follows this change after a certain time delay. The physical cause is the time related to heat transfer from the process media through the thermowell and the insert to the sensor element (thermocouple). The manner in which the reading follows the change in temperature of the assembly over time is referred to as the response time. Variables that influence or impact the response time are:

- Wall thickness of thermowell
- Spacing between thermocouple insert and thermowell
- Sensor packing
- Process parameters such as media, flow velocity, etc.

Maximum measured error

Thermocouples corresponding to ASTM E230

Type	Temperature range	Standard tolerance (IEC class 2)	Special tolerance (IEC class 1)
		[°C] whichever is greater	[°C] whichever is greater
E	0 to 870 °C (32 to 1600 °F)	±1.7 or ±0.5%	±1 or ±0.4%
J	0 to 760 °C (32 to 1400 °F)	±2.2 or ±0.75%	±1.1 or ±0.4%
K	0 to 1260 °C (32 to 2300 °F)	±2.2 or ±0.75%	±1.1 or ±0.4%
T	0 to 370 °C (32 to 700 °F)	±1 or 0.75%	±0.5 or ±0.4%
N	0 to 1260 °C (32 to 2300 °F)	±2.2 or ±0.75%	±1.1 or ±0.4%

 For measurement errors in °F, calculate using equation above in °C, then multiply the outcome by 1.8.

Transmitter long-term stability

≤ 0.1 °C (0.18 °F) / year or ≤ 0.05 % / year

Data under reference conditions; % relates to the set span. The larger value applies.

Insulation resistanceInsulation resistance for MgO insulated thermocouples with ungrounded hot junction between terminals and probe sheath, test voltage 500 V_{DC}.

1000 MΩ at 25 °C (77 °F)

These values for insulation resistance also apply between each thermocouple wire at single and duplex constructions with ungrounded hot junction.

Calibration specifications

The manufacturer provides comparison temperature calibrations from -20 to +300 °C (-4 to +573 °F) on the ITS-90 (International Temperature Scale). Calibrations are traceable to standards maintained by the National Institute of Standards and Technology (NIST). Calibration services are in conformance with ASTM E220. The report of calibration is referenced to the serial number of the RTD assembly.

Three point calibrations are provided, given that the specified temperatures are within the recommended range and the minimum length requirements are met as specified. The minimum length is based on overall length 'x' of the spring loaded insert.

Installation conditions**Orientation**

No restrictions.

Installation instructions

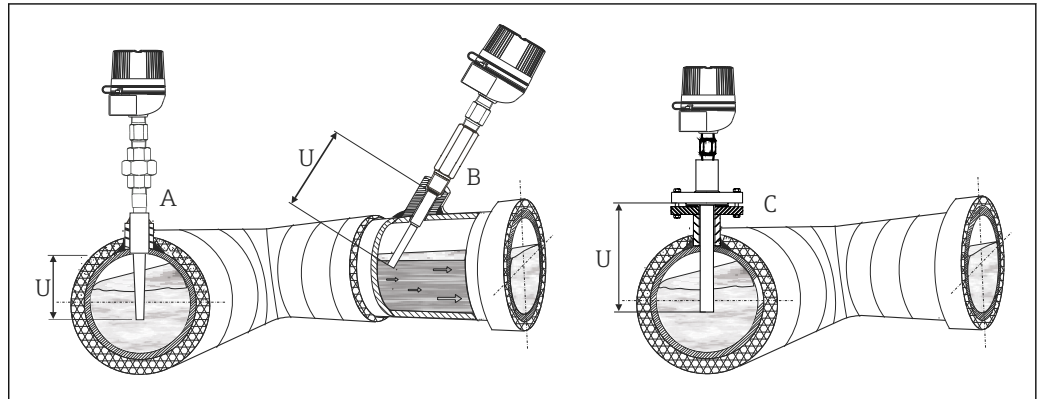

8 Installation examples

A-C In pipes with a small cross section the thermowell tip should reach or extend slightly past the center line of the pipe (= U)

- B Threaded, angled installation of T53 assembly
- C Flange installation of T54 assembly

The immersion length of the thermometer influences the accuracy. If the immersion length is too small then errors in the measurement are caused by heat conduction via the process connection and the container wall. If installing into a pipe then the immersion length should be at least half of the pipe diameter. A further solution could be an angled (tilted) installation (see B). When determining the immersion length all thermometer parameters and the process to be measured must be taken into account (e.g. flow velocity, process pressure).

- Installation possibilities: Pipes, tanks or other plant components
- Minimum immersion length per ASTM E644, $\Delta T \leq 0.05 \text{ }^\circ\text{C}$ (0.09 °F):

For temperature assemblies with thermowell (T53 and T54) the minimum immersion is the depth to which the thermowell is immersed in the medium, measured from the tip. To minimize errors from ambient temperature the following minimum immersion lengths are recommended:

Construction	Minimum immersion
Stepped thermowell	63.5 mm (2.5 in)
Tapered thermowell	114.3 mm (4.5 in)
¾" straight thermowell	101.6 mm (4 in)
Weld-in thermowell	114.3 mm (4.5 in)

i T55 assemblies can only be used in existing thermowells.

Shock and vibration resistance

4 g/2 to 150 Hz as per IEC 60068-2-6

Environment

Ambient temperature range

Terminal head	Temperature in °C (°F)
Without mounted head transmitter	Depends on the terminal head used and the cable gland or fieldbus connector, see 'Terminal heads' section
With mounted head transmitter	-40 to 85 °C (-40 to 185 °F) SIL mode (HART 7 transmitter): -40 to 70 °C (-40 to 158 °F)

Terminal head	Temperature in °C (°F)
With mounted head transmitter and display	-20 to 70 °C (-4 to 158 °F)
With mounted field transmitter	<ul style="list-style-type: none"> ▪ Without display: -40 to 85 °C (-40 to 185 °F) ▪ With display and/or integrated overvoltage protection module: -40 to +80 °C (-40 to +176 °F) ▪ SIL mode: -40 to +75 °C (-40 to +167 °F)

Shock and vibration resistance

4 g/2 to 150 Hz as per IEC 60068-2-6

Mechanical construction

Design, dimensions

All dimensions in inch. For values related to the graphics please refer to the tables and equations below.

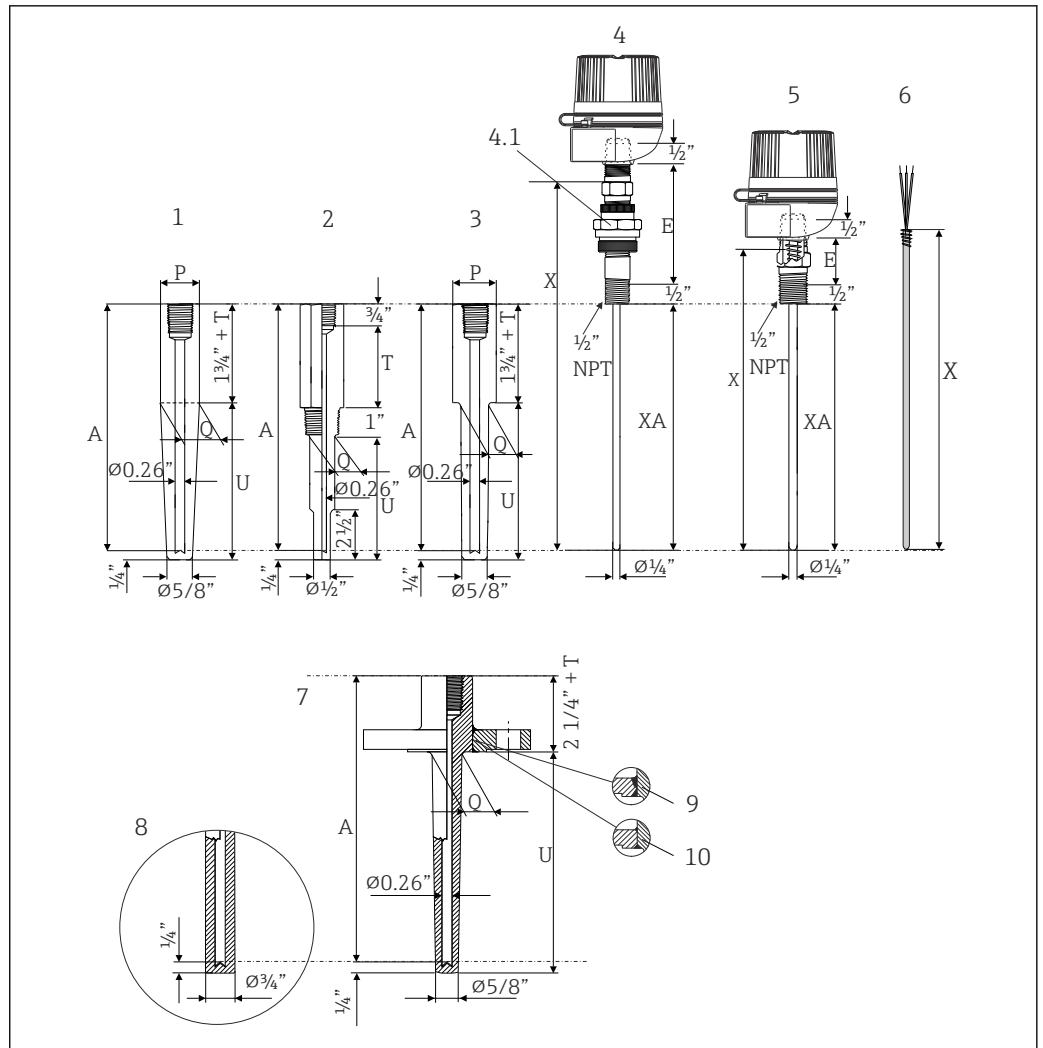

A0045620

9 Dimensions of the sensor assemblies.

- 1 T53 weld-in thermowell (tapered)
- 2 T53 threaded thermowell (stepped)
- 3 T53 socket weld thermowell (tapered)
- 4 T53/T54 extension, nipple-XP-union-nipple (NUN), without thermowell
- 4.1 XP certified union
- 5 T53/T54 extension hex nipple without thermowell
- 6 Spring loaded insert (TU121)
- 7 T54 flange thermowell (tapered)
- 8 Straight thermowell tip
- 9 Full penetration weld thermowell
- 10 Standard weld thermowell
- E Extension length
- P Pipe size
- Q Thermowell root diameter
- T Lag dimension
- U Thermowell immersion length
- XA Immersion length thermocouple sensor
- A Drill depth of thermowell
- X Overall insert length

i The spring travel of the insert is 1/2".

i Tolerance of XA length = +/- 1/4".

All thermowells are marked with a material ID, CRN (Canadian Registration Number) and heat number.

Dimensions of T53						
U	E (nominal dimension)	T	Process connection	Shape of Thermowell	Ø Q1	Ø Q2
63.5 mm (2.5 in)	Material: Steel or 316	76.2 mm (3 in) or specified length 25.4 to 152.4 mm (1 to 6 in) in ½" increments	½" NPT	Stepped	16 mm (⅝ in)	12.7 mm (½ in)
114.3 mm (4.5 in)				Tapered	16 mm (⅝ in)	16 mm (⅝ in)
	190.5 mm (7.5 in)		Hex nipple = 25.4 mm (1 in)	¾" NPT	Stepped	19.05 mm (¾ in)
Tapered					22.3 mm (⅞ in)	16 mm (⅝ in)
266.7 mm (10.5 in)	Nipple Union Nipple (NUN) = 101.6 mm (4 in) 177.8 mm (7 in)		1" NPT	Stepped	22.3 mm (⅞ in)	12.7 mm (½ in)
				Tapered	26.9 mm (1 ⅛ in)	16 mm (⅝ in)
342.9 mm (13.5 in)			¾" socket weld	Stepped	19.05 mm (¾ in)	12.7 mm (½ in)
				Tapered	22.3 mm (⅞ in)	16 mm (⅝ in)
419.1 mm (16.5 in)			1" socket weld	Stepped	22.3 mm (⅞ in)	12.7 mm (½ in)
				Tapered	25.4 mm (1 in)	16 mm (⅝ in)
571.5 mm (22.5 in)		¾" weld in	Tapered	26.6 mm (1.050 in)	16 mm (⅝ in)	
			1" weld in	Tapered	33.4 mm (1.315 in)	16 mm (⅝ in)
specified length						
50.8 to 609.6 mm (2 to 24 in) in ½" increments						
Immersion length RTD sensor = Thermowell drilled length XA = A = U + 38.1 mm (1.5 in) + T						
Insert overall length X = A + E						
P = Pipe size						
<ul style="list-style-type: none"> ▪ Nom. ¾"; Dia. = 1.050" ▪ Nom. 1"; Dia. = 1.315" 						

Dimensions of T54						
Flange rating: ASME B16.5						
U	E	T	Flange size	Shape of thermowell	Ø Q1	Ø Q2
50.8 mm (2 in)	Material: Steel or 316SS	specified length 25.4 to 254 mm (1 to 10 in) ½" increments	1"	Straight	19.05 mm (¾ in)	19.05 mm (¾ in)
101.6 mm (4 in)				Tapered	22.3 mm (⅞ in)	16 mm (⅝ in)
177.8 mm (7 in)	Hex nipple = 25.4 mm (1 in)		1 ½" and larger	Straight	19.05 mm (¾ in)	19.05 mm (¾ in)
254 mm (10 in)				Tapered	26.9 mm (1 ⅛ in)	16 mm (⅝ in)
330.2 mm (13 in)	Nipple Union Nipple (NUN) = 101.6 mm (4 in) 177.8 mm (7 in)					
406.4 mm (16 in)						
558.8 mm (22 in)						
specified length						
50.8 to 609.6 mm (2 to 24 in) in ½" increments						
Immersion length RTD sensor - Thermowell drilled length XA = A = U + 50.8 mm (2 in) + T						
Insert overall length X = A + E						

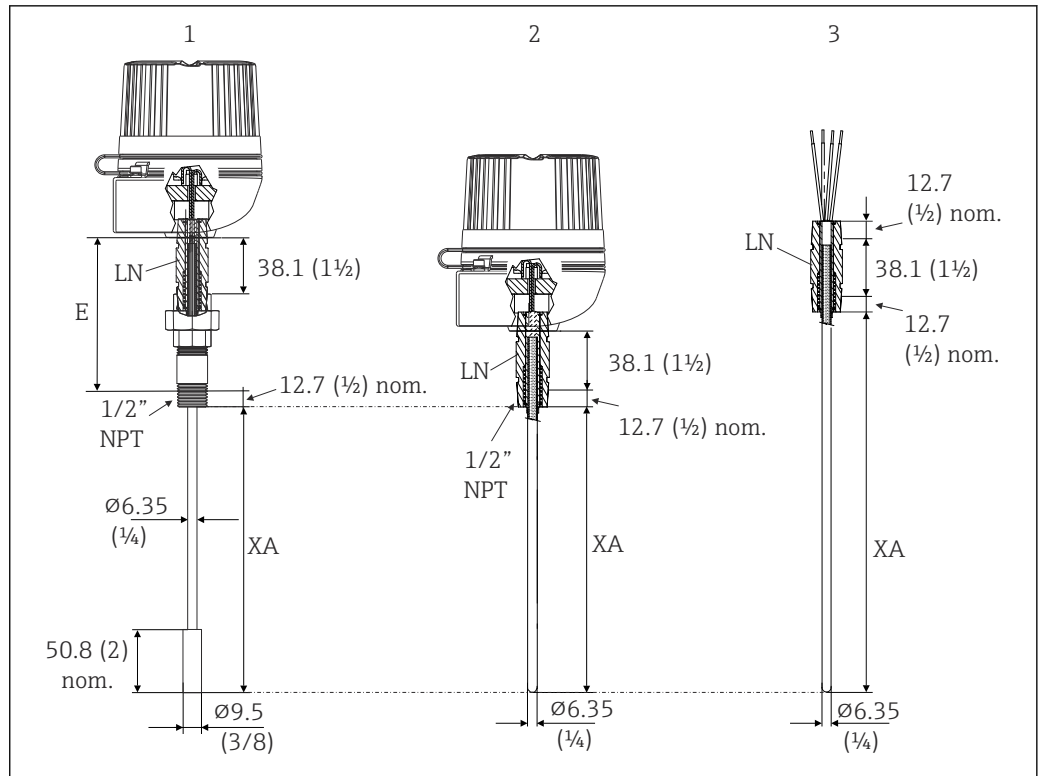

A0045725

10 Design and dimensions of T55 (without thermowell), all dimensions in mm (in)

- 1 T55 extension, lamination nipple union nipple
- 2 T55 extension, lamination nipple
- 3 Spring loaded insert (TU221)
- E Extension length (nominal dimension)
- LN Lamination nipple (flamepath nipple)
- XA Insert immersion length

i The spring travel of the insert is 1/2".

i When ordering a sensor with a 3/8" diameter, only the bottom 2" will have an outer diameter of 3/8".

Dimensions of T55 (without thermowell)		Extension E
Immersion length	Thermocouple sensor XA	Lamination Nipple Union Nipple (LUN) = 101.6 mm (4 in) or 177.8 mm (7 in)
	specified length 101.6 to 2540 mm (4 to 100 in) in 1/2" increments	
	Thermocouple sensor XA for spring loaded insert TU221 as spare part insert for Lamination Nipple Union Nipple (LUN) version	
	Spring travel of the insert = 1/2"	

Hot or measuring junction

Ungrounded junction

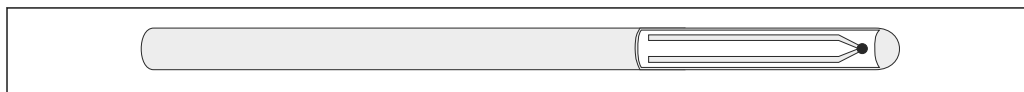

A0026087

 11 Ungrounded junction

The welded thermocouple junction is fully isolated from the welded closed end sheath. This junction provides electrical isolation to reduce problems associated with electrical interference. Ungrounded junctions are also recommended for use in extreme positive or negative temperatures, rapid thermal cycling and for ultimate corrosion resistance of the sheath alloy. iTEMP transmitters have an excellent noise immunity (EMC) meeting all requirements listed under IEC 61326 for use in noisy environments.

 Dual ungrounded elements supplied with individually isolated junctions.

Weight

1 to 30 lbs

Material

Process connection and thermowell

The temperatures for continuous operation specified in the following table are only intended as reference values for use of the various materials in air and without any significant compressive load. The maximum operation temperatures are reduced considerably in some cases where abnormal conditions such as high mechanical load occur or in aggressive media.

Material name	Short form	Recommended max. temperature for continuous use in air	Properties
AISI 316/ 1.4401	X5CrNiMo17-12-2	650 °C (1202 °F) ¹⁾	<ul style="list-style-type: none"> ▪ Austenitic, stainless steel ▪ High corrosion resistance in general ▪ Particularly high corrosion resistance in chlorine-based and acidic, non-oxidizing atmospheres through the addition of molybdenum (e.g. phosphoric and sulfuric acids, acetic and tartaric acids with a low concentration)
AISI 316L/ 1.4404 1.4435	X2CrNiMo17-12-2 X2CrNiMo18-14-3	650 °C (1202 °F)	<ul style="list-style-type: none"> ▪ Austenitic, stainless steel ▪ High corrosion resistance in general ▪ Particularly high corrosion resistance in chlorine-based and acidic, non-oxidizing atmospheres through the addition of molybdenum (e.g. phosphoric and sulfuric acids, acetic and tartaric acids with a low concentration) ▪ Increased resistance to intergranular corrosion and pitting ▪ Compared to 1.4404, 1.4435 has even higher corrosion resistance and a lower delta ferrite content



Material name	Short form	Recommended max. temperature for continuous use in air	Properties
Alloy600	NiCr15Fe	1 100 °C (2 012 °F)	<ul style="list-style-type: none"> ■ A nickel/chromium alloy with very good resistance to aggressive, oxidizing and reducing atmospheres, even at high temperatures ■ Resistant to corrosion caused by chlorine gas and chlorinated media as well as many oxidizing mineral and organic acids, sea water etc. ■ Corrosion from ultrapure water ■ Not to be used in a sulfur-containing atmosphere
AISI A105/1.0460	C22.8	450 °C (842 °F)	<ul style="list-style-type: none"> ■ Heat-resistant steel ■ Resistant in nitrogen-containing atmospheres an atmospheres that are low in oxygen; not suitable for acids or other aggressive media ■ Often used in steam generators, water and steam pipes, pressure vessels

1) Can be used to a limited extent up to 800 °C (1472 °F) for low compressive loads and in non-corrosive media. Please contact your Endress+Hauser sales team for further information.

Process connection

The process connection is the means of connecting the thermometer to the process. The following process connections are available:

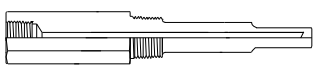
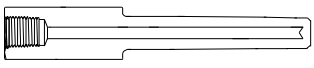
T53

Thread	Version
 <small>A0026110</small>	NPT thread
	NPT 1/2"
	NPT 3/4"
 <small>A0026111</small>	NPS for socket weld
	NPS 3/4"
 <small>A0026108</small>	NPS for weld-in
	NPS 3/4"
	NPS 1"

T54

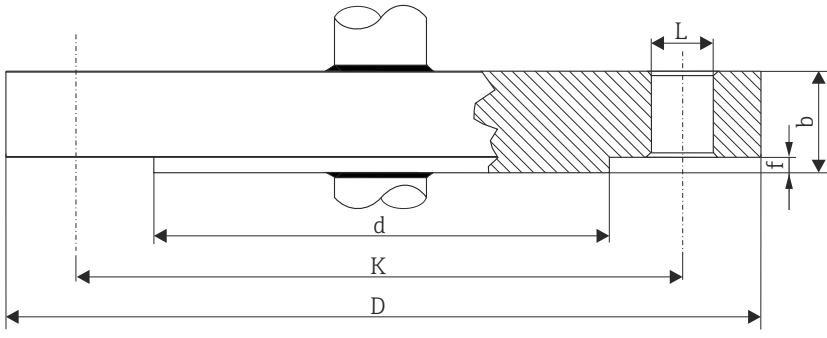
Flange	
 <small>A0010471</small>	
<p>For detailed information on the flange dimensions refer to the following flange standard: ANSI/ASME B16.5</p>	<p>The flange material must be the same as of the stem of the thermowell.</p>

T55

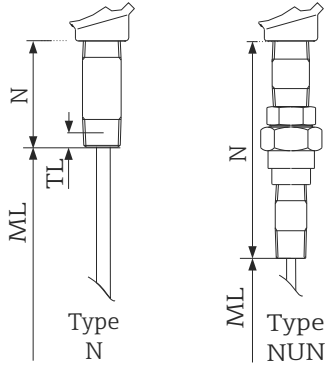
Type	Thermowell connection	Extension neck lengths in mm (in)
	Type N	25.4 mm (1 in)
	Type NUN	101.6 mm (4 in) 177.8 mm (7 in)

Housing

Terminal heads

All terminal heads have an internal shape and size in accordance with DIN EN 50446, flat face and a thermometer connection with a 1/2" NPT thread. All dimensions in mm (in). Specifications without head transmitter installed. For ambient temperatures with head transmitter installed, see the 'Environment' section.

As a special feature, Endress+Hauser offers terminal heads with optimized terminal accessibility for easy installation and maintenance.

 Some of the specifications listed below may not be available on this product line.

As illustrated in the following diagram, the length of the extension neck can influence the temperature in the terminal head. This temperature must remain within the limit values defined in the "Operating conditions" section.

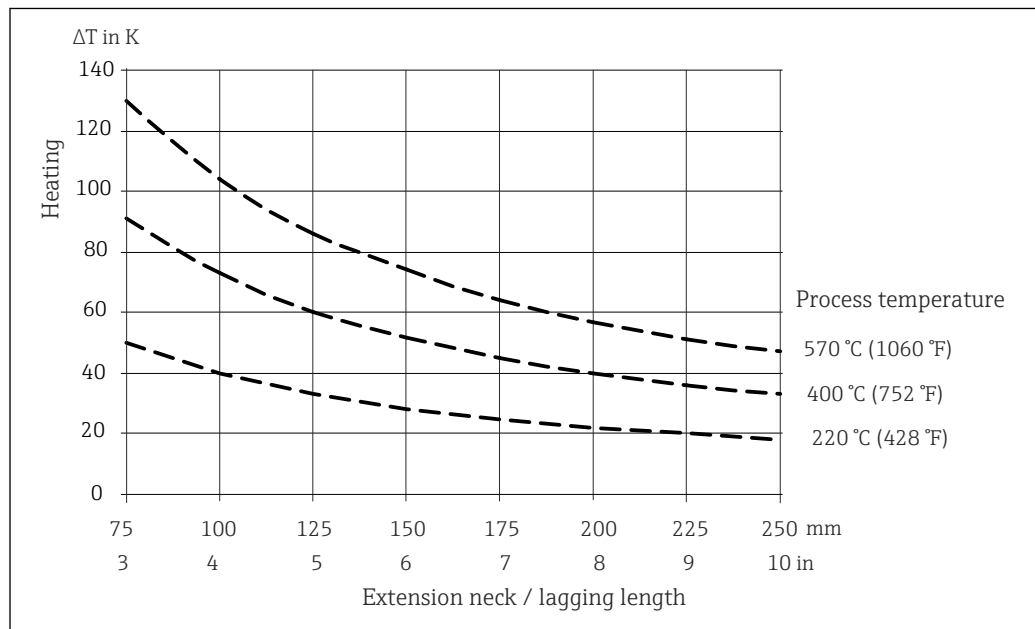

 12 Heating of the terminal head as a function of the process temperature. Temperature in terminal head = ambient temperature 20 °C (68 °F) + ΔT

The diagram can be used to calculate the transmitter temperature.

Example: At a process temperature of 220 °C (428 °F) and with a lagging length of 100 mm (3.94 in), the heat conduction is 40 K (72 °F). The transmitter temperature is therefore 40 K (72 °F) plus the ambient temperature, e.g. 25 °C (77 °F): 40 K (72 °F) + 25 °C (77 °F) = 65 °C (149 °F).

Result: The temperature of the transmitter is o.k., the length of the lagging is sufficient.

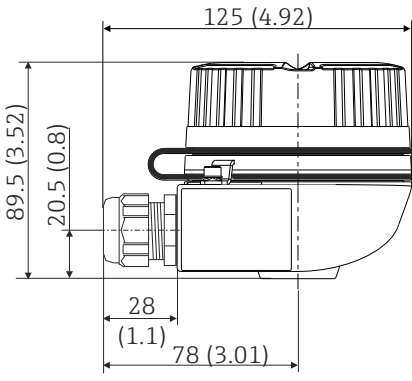
TA30H	Specification
 <p style="text-align: right; font-size: small;">A0009832</p>	<ul style="list-style-type: none"> ▪ Flameproof (XP) version, explosion-protected, captive screw cap, available with one or two cable entries ▪ Degree of protection: IP 66/68, NEMA Type 4x encl. Ex-version: IP 66/67 ▪ Temperature: -50 to +150 °C (-58 to +302 °F) for rubber seal without cable gland (observe max. permitted temperature of cable gland!) ▪ Material: <ul style="list-style-type: none"> ▪ Aluminum with polyester powder coating ▪ Stainless steel 316L without coating ▪ Klüber Syntheso Glep 1 dry-film lubricant ▪ Thread: ½" NPT, ¾" NPT, M20x1.5, G½" ▪ Extension neck/thermowell connection: M20x1.5 or ½" NPT ▪ Color of aluminum head: blue, RAL 5012 ▪ Color of aluminum cap: gray, RAL 7035 ▪ Weight: <ul style="list-style-type: none"> ▪ Aluminum: approx. 640 g (22.6 oz) ▪ Stainless steel: approx. 2 400 g (84.7 oz) <p>i If the housing cover is unscrewed: Before tightening, clean the thread in the cover and housing base and lubricate if necessary (Recommended lubricant: Klüber Syntheso Glep 1)</p>

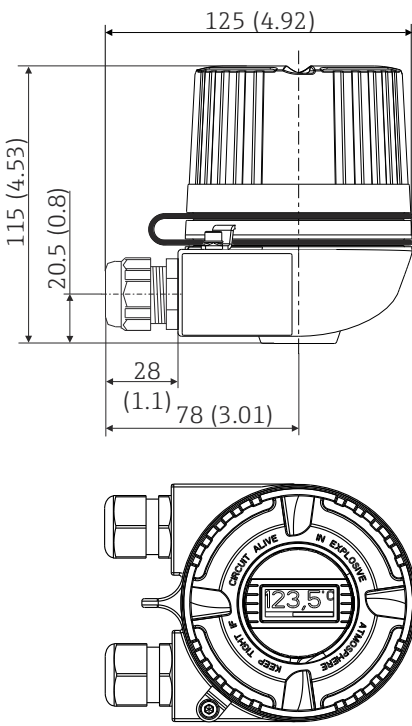
TA30H with display window in cover	Specification
 <p style="text-align: right; font-size: small;">A0009831</p>	<ul style="list-style-type: none"> ▪ Flameproof (XP) version, explosion-protected, captive screw cap, available with one or two cable entries ▪ Degree of protection: IP 66/68, NEMA Type 4x encl. Ex-version: IP 66/67 ▪ Temperature: -50 to +150 °C (-58 to +302 °F) for rubber seal without cable gland (observe max. permitted temperature of cable gland!) ▪ Material: <ul style="list-style-type: none"> ▪ Aluminum; polyester powder coated ▪ Stainless steel 316L without coating ▪ Klüber Syntheso Glep 1 dry-film lubricant ▪ Display window: single-pane safety glass according to DIN 8902 ▪ Thread: ½" NPT, ¾" NPT, M20x1.5, G½" ▪ Extension neck/thermowell connection: M20x1.5 or ½" NPT ▪ Color of aluminum head: blue, RAL 5012 ▪ Color of aluminum cap: gray, RAL 7035 ▪ Weight: <ul style="list-style-type: none"> ▪ Aluminum approx. 860 g (30.33 oz) ▪ Stainless steel approx. 2 900 g (102.3 oz) ▪ Head transmitter optionally available with TID10 display <p>i If the housing cover is unscrewed: Before tightening, clean the thread in the cover and housing base and lubricate if necessary (Recommended lubricant: Klüber Syntheso Glep 1)</p>

Field transmitter

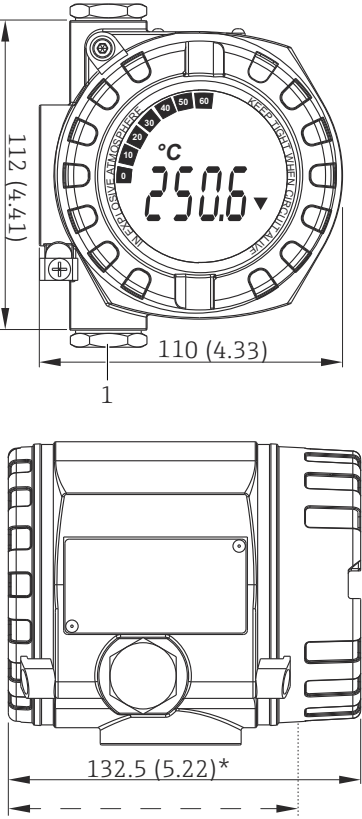
Temperature field transmitter iTEMP TMT162	Specification
 <p data-bbox="416 1144 938 1171">1 Instrument connection for direct mounting assembly</p> <p data-bbox="416 1196 874 1223">* Dimensions without display = 112 mm (4.41 in)</p>	<ul style="list-style-type: none"> ■ Separate electronics compartment and connection compartment ■ Protection class: IP67, NEMA type 4x ■ Material: Die-cast aluminum housing AlSi10Mg with powder coating on polyester base or stainless steel 316L ■ Display rotatable in 90° increments ■ Cable entry: 2x ½" NPT ■ Brilliant backlit display with ease of visibility in bright sunshine or pitch darkness ■ Gold plated terminals to avoid corrosion and additional measurement errors ■ SIL certification as per IEC 61508:2010 (HART-protocol)

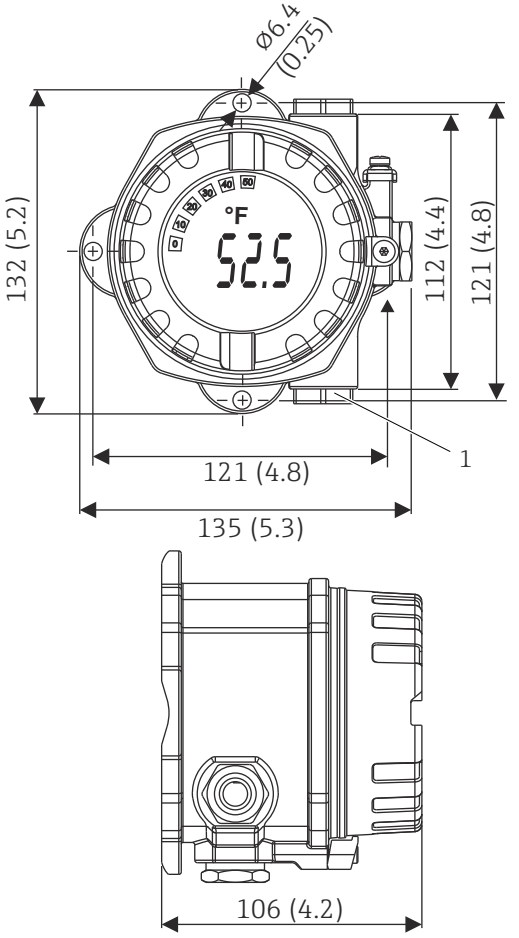
Temperature field transmitter iTEMP TMT142B	Specification
 <p>1 Instrument connection for direct mounting assembly</p> <p>A0047368</p>	<ul style="list-style-type: none"> ■ Protection class: IP66/67, NEMA type 4x ■ Material: Die-cast aluminum housing AlSi10Mg with powder coating on polyester base or stainless steel 316L ■ Display rotatable in 90° increments ■ Integrated Bluetooth® interface for wireless measured value display and parameter configuration, optional ■ Brilliant backlit display with ease of visibility in bright sunshine or pitch darkness ■ Gold plated terminals to avoid corrosion and additional measurement errors

Certificates and approvals

Current certificates and approvals that are available for the product can be selected via the Product Configurator at www.endress.com:

1. Select the product using the filters and search field.
2. Open the product page.
3. Select **Configuration**.

Ordering information

Detailed ordering information is available from your nearest sales organization www.addresses.endress.com or in the Product Configurator at www.endress.com:

1. Select the product using the filters and search field.
2. Open the product page.

3. Select Configuration.

Product Configurator - the tool for individual product configuration

- Up-to-the-minute configuration data
- Depending on the device: Direct input of measuring point-specific information such as measuring range or operating language
- Automatic verification of exclusion criteria
- Automatic creation of the order code and its breakdown in PDF or Excel output format
- Ability to order directly in the Endress+Hauser Online Shop

Accessories

Various accessories, which can be ordered with the device or subsequently from Endress+Hauser, are available for the device. Detailed information on the order code in question is available from your local Endress+Hauser sales center or on the product page of the Endress+Hauser website:

www.endress.com.

Device-specific accessories

Mounting bracket	SS316L, for tube 1.5...3" Order code: 51007995
Adapter	M20x1.5 - 1/2" NPT cable entry Order code: 51004387
Cable gland	1/2" NPT, D4.5-8.5, IP 68 Order code: 51006845
Configuration kit TXU10	Configuration kit for PC-programmable transmitter with setup software and interface cable for PC with USB port Order code: TXU10-xx
Integrated overvoltage protection module	The module protects the electronics from overvoltage. Available for TMT162 housing.

Service-specific accessories



Accessories	Description
Applicator	<p>Software for selecting and sizing Endress+Hauser measuring devices:</p> <ul style="list-style-type: none"> ▪ Calculation of all the necessary data for identifying the optimum measuring device: e.g. pressure loss, accuracy or process connections. ▪ Graphic illustration of the calculation results <p>Administration, documentation and access to all project-related data and parameters over the entire life cycle of a project.</p> <p>Applicator is available:</p> <ul style="list-style-type: none"> ▪ Via the Internet: https://portal.endress.com/webapp/applicator ▪ On CD-ROM for local PC installation.
Configurator	<p>Product Configurator - the tool for individual product configuration</p> <ul style="list-style-type: none"> ▪ Up-to-the-minute configuration data ▪ Depending on the device: Direct input of measuring point-specific information such as measuring range or operating language ▪ Automatic verification of exclusion criteria ▪ Automatic creation of the order code and its breakdown in PDF or Excel output format ▪ Ability to order directly in the Endress+Hauser Online Shop <p>The Configurator is available on the Endress+Hauser website: www.endress.com -> Click "Corporate" -> Select country -> Click "Products" -> Select the product using the filters and search field -> Open product page -> The "Configure" button to the right of the product image opens the Product Configurator.</p>

W@M	<p>Life cycle management for your plant</p> <p>W@M supports with a wide range of software applications over the entire process: from planning and procurement, to the installation, commissioning and operation of the measuring devices. All the relevant device information, such as the device status, spare parts and device-specific documentation, is available for every device over the entire life cycle.</p> <p>The application already contains the data of your Endress+Hauser device. Endress+Hauser also takes care of maintaining and updating the data records.</p> <p>W@M is available:</p> <ul style="list-style-type: none"> ▪ Via the Internet: www.endress.com/lifecyclemanagement ▪ On CD-ROM for local PC installation.
-----	---

FieldCare SFE500	<p>FDT-based plant asset management tool from Endress+Hauser. It can configure all smart field units in your system and helps you manage them. By using the status information, it is also a simple but effective way of checking their status and condition.</p> <p> For details, see Operating Instructions BA00027S and BA00065S</p>
------------------	--

DeviceCare SFE100	<p>Configuration tool for devices via fieldbus protocols and Endress+Hauser service protocols.</p> <p>DeviceCare is the tool developed by Endress+Hauser for the configuration of Endress+Hauser devices. All smart devices in a plant can be configured via a point-to-point or point-to-bus connection. The user-friendly menus enable transparent and intuitive access to the field devices.</p> <p> For details, see Operating Instructions BA00027S</p>
-------------------	---

System components

Accessories	Description
Process display unit RIA15	<p>The display unit records the analog measuring signal from the head transmitter and shows this on the display. The LC display shows the current measured value in digital form and as a bar graph indicating a limit value violation. The process display unit is integrated in the 4 to 20 mA or HART® loop and is powered directly from the current loop. Optionally up to four of a sensor's HART® process variables can be displayed.</p> <p> For details, see the "Technical Information" document TI01043K/09/EN</p>
RN42 active barrier, wide range power supply	<p>1-channel wide range supply and active barrier for safe isolation of 4 to 20 mA standard signal circuits.</p> <p> For details, see "Technical Information", TI01584K</p>

Supplementary documentation

The following types of documentation are available on the product pages and in the Download Area of the Endress+Hauser website (www.endress.com/downloads) (depending on the selected device version):

Document	Purpose and content of the document
Technical Information (TI)	<p>Planning aid for your device</p> <p>The document contains all the technical data on the device and provides an overview of the accessories and other products that can be ordered for the device.</p>
Brief Operating Instructions (KA)	<p>Guide that takes you quickly to the 1st measured value</p> <p>The Brief Operating Instructions contain all the essential information from incoming acceptance to initial commissioning.</p>

Document	Purpose and content of the document
Operating Instructions (BA)	<p>Your reference document</p> <p>The Operating Instructions contain all the information that is required in various phases of the life cycle of the device: from product identification, incoming acceptance and storage, to mounting, connection, operation and commissioning through to troubleshooting, maintenance and disposal.</p>
Description of Device Parameters (GP)	<p>Reference for your parameters</p> <p>The document provides a detailed explanation of each individual parameter. The description is aimed at those who work with the device over the entire life cycle and perform specific configurations.</p>
Safety Instructions (XA)	<p>Depending on the approval, Safety Instructions (XA) are supplied with the device. The Safety Instructions are an integral part of the Operating Instructions.</p> <p> Information on the Safety Instructions (XA) that are relevant for the device is provided on the nameplate.</p>
Supplementary device-dependent documentation (SD/FY)	<p>Always comply strictly with the instructions in the relevant supplementary documentation. The supplementary documentation is an integral part of the device documentation.</p>



www.addresses.endress.com
