



Level



Pressure



Flow



Temperature



Liquid  
Analysis



Registration



Systems  
Components



Services



Solutions

## Operating Instructions

# Analog Transmitter AT1000 AT1

Alarm Transmitter for Mechanical Level Gauges

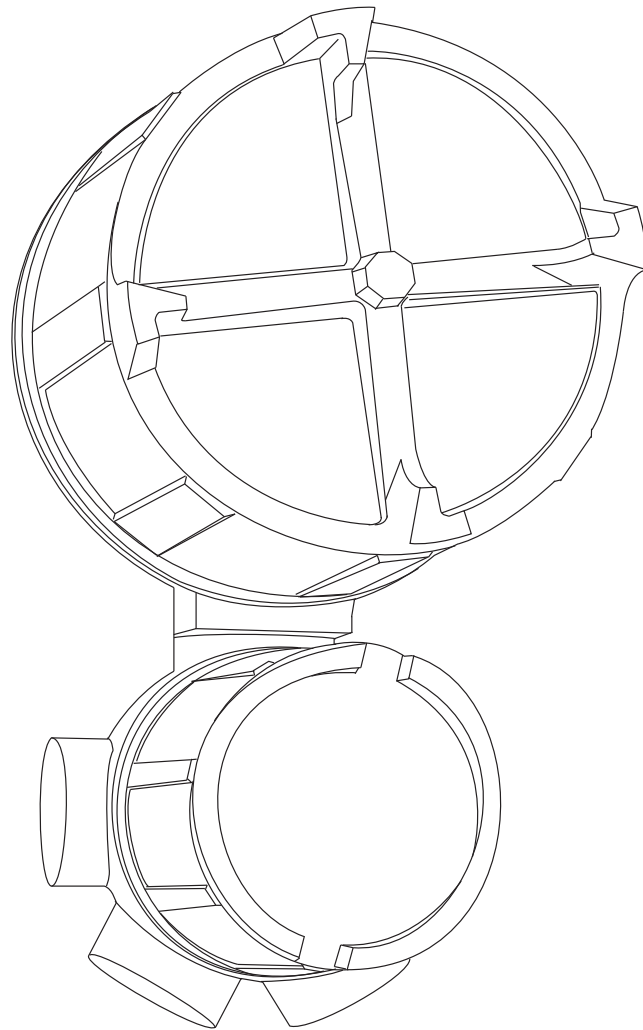

# Table of Contents

<b>1</b>	<b>Safety Instructions</b> .....	<b>4</b>	<b>4</b>	<b>Wiring</b> .....	<b>16</b>
1.1	Designated Use .....	4			
1.2	Installation, Commissioning, and Operation .....	4	<b>5</b>	<b>Operation</b> .....	<b>18</b>
1.3	Operational Safety .....	4	5.1	Span Adjustment .....	18
1.4	Notes on Safety Conventions and Symbols .....	5	<b>6</b>	<b>Maintenance</b> .....	<b>19</b>
<b>2</b>	<b>Identification</b> .....	<b>6</b>	<b>7</b>	<b>Troubleshooting</b> .....	<b>20</b>
2.1	Device Designation .....	6	7.1	Spare Parts .....	20
2.2	Ordering Information .....	7	7.2	Troubleshooting .....	23
2.3	Scope of Delivery .....	9	7.3	Return .....	23
2.4	Registered Trademarks .....	9	7.4	Disposal .....	23
<b>3</b>	<b>Installation</b> .....	<b>10</b>	7.5	Contact Addresses of Endress+Hauser .....	23
3.1	Incoming Acceptance, Transport, Storage .....	10	<b>8</b>	<b>Technical Data</b> .....	<b>24</b>
3.2	Installation Conditions .....	10			
3.3	Installation and Setting Transmitter .....	12			

# 1 Safety Instructions

## 1.1 Designated Use

AT1 analog transmitter is designed to be installed onto LT and LTC series level gauging systems. The device transmits the level information into electric current, voltage, and resistance signals. It can also be equipped with a maximum of six alarm contact signals.

In addition to transmitting the level, contact signals can be received by this transmitter alone, enabling easy control of the valve and pump.

## 1.2 Installation, Commissioning, and Operation

- Mounting, electrical installation, start-up, and maintenance of the instrument may only be performed by trained personnel authorized by the operator of the facility.
- Personnel must read and understand these installation instructions before performing the procedures.
- The instrument may only be operated by personnel who are authorized and trained by the operator of the facility. All instructions in this manual must be observed.
- The installer must make sure that the measuring system is correctly wired according to the wiring diagrams. The measuring system must be grounded.
- Observe all law and regulations applicable and valid for your country and pertaining to the opening and repairing of electrical devices.

## 1.3 Operational Safety

### 1.3.1 Hazardous Areas

Measuring systems for use in hazardous environments are accompanied by separate "Ex documentation", which is an integral part of this operating manual. Strict compliance with the installation instructions and ratings as stated in this supplementary documentation is mandatory.

- Ensure that all personnel are suitably qualified.
- Observe the specifications in the certificate as pipe as national and local regulations.













#### **Caution!**

Changes or modifications not expressly approved by the party responsible for compliance could void the user's authority to operate the equipment.

## 1.4 Notes on Safety Conventions and Symbols

To highlight safety-relevant or alternative operating procedures in this manual, the following conventions have been used, each indicated by a corresponding symbol on the left.

Safety Conventions	
	<b>Warning!</b> Indicates an action or procedure that, if not performed correctly, will lead to personal injury, a safety hazard, or destruction of the instrument
	<b>Caution!</b> Indicates an action or procedure that, if not performed correctly, may lead to personal injury or malfunction of the instrument
	<b>Note!</b> Indicates an action or procedure that, if not performed correctly, may indirectly affect operation or lead to an unexpected instrument response.
Explosion Protection	
	<b>Device certified for Use in Explosion Hazardous Area</b> If the device has this symbol embossed on its name plate, it can be installed in an explosion hazardous area.
	<b>Explosion Hazardous Areas</b> Symbol used in drawings to indicate explosion hazardous areas. Devices located in and wiring entering areas designated as “explosion hazardous areas” must conform to the stated type of protection.
	<b>Safe Area (non-explosion hazardous area)</b> Symbol used in drawings to indicate, if necessary, non-explosion hazardous areas. Devices located in safe areas still require a certificate if wiring enters into explosion hazardous areas
Electrical Symbols	
	<b>Direct Voltage</b> A terminal to or from which a direct current or voltage may be applied or supplied
	<b>Alternating Voltage</b> A terminal to or from which an alternating (sine-wave) current or voltage may be applied or supplied
	<b>Grounded Terminal</b> A grounded terminal, that is already grounded by means of an earth grounding system for the purpose of the operator
	<b>Protective Grounding (earth) Terminal</b> A terminal that must be connected to an earth ground prior to making any other connection to the equipment
	<b>Equipotential Connection (earth bonding)</b> A connection that must be made to the facility grounding system, such as a star-shaped connection grounding system or equipotential line, according practices of the country or company.

## 2 Identification

### 2.1 Device Designation

#### 2.1.1 Nameplate

The follow technical data are given on the instrument nameplate:

定 格 / R a t i n g	<b>Endress+Hauser</b> 	①	Order cord	
	液面計発信器/Transmitter	Order code <input type="text"/>	②	Serial number
	Serial no. <input type="text"/>	Serial no. <input type="text"/>	③	Measuring range
	Range 0 ~ <input type="text"/> m	Range 0 ~ <input type="text"/> m	④	Explosion model
	防爆型式 / Ex proof model : <input type="text"/>	防爆型式 / Ex proof model : <input type="text"/>	⑤	Protection class
	防爆構造 / Protection class : <input type="text"/>	防爆構造 / Protection class : <input type="text"/>	⑥	Power
	電源 / Power <input type="text"/>	電源 / Power <input type="text"/>	⑦	Analog Output
	出力 / Output DC <input type="text"/> <input type="text"/>	出力 / Output DC <input type="text"/> <input type="text"/>	⑧	Analog output
	接点出力 / Contact output <input type="text"/> (1接点容量/1 contact)	接点出力 / Contact output <input type="text"/> (1接点容量/1 contact)	⑨	Contact output
	周囲温度 / Ambient temp.: -10 °C ~ +40 °C	周囲温度 / Ambient temp.: -10 °C ~ +40 °C	⑩	Contact output

警告：通電状態では蓋を開けないでください。 IP65  
 Warning: Do not open the cover when energized. IP65

エンドレスハウザー山梨株式会社 Yamanashi 406-0846  
 Endress+Hauser Yamanashi Co.,Ltd. Made in Japan  
 NP-1552-7

Figure 1: TIIS approval type

## 2.2 Ordering Information

<b>010</b>	<b>Output:</b>	1	4 - 20mA
		2	10 - 50mA
		3	0 - 1mA
		4	0 - 20mA
		5	0 - 10mVDC
		6	0 - 1VDC
		9	Special version, TSP-no. to be spec.
<b>020</b>	<b>Power Type:</b>	1	AC
		2	DC
<b>030</b>	<b>Alarm Output:</b>	0	Not used
		2	2 - point
		4	4 - point
		6	6 - point
<b>040</b>	<b>Approval:</b>	B	Flame proof d2G4, TIS + cable gland
		E	Flame proof d2G4, TIS
		W	Weather proof IP65
		Y	Special version, TSP-no. to be spec.
<b>050</b>	<b>Function:</b>	0	Basic version
		9	Special version, TSP-no. to be spec.
<b>060</b>	<b>Power Supply:</b>	1	100VAC, 50/60Hz
		2	110VAC, 50/60Hz
		3	200VAC, 50/60Hz
		4	220VAC, 50/60Hz
		5	24VDC
		9	Special version, TSP-no. to be spec.
<b>070</b>	<b>Cable Entry:</b>	A	1 x thread G 3/4
		B	2 x thread G 3/4
		C	1 x thread G 1-1/2
		D	1 x thread G 1-1/2, 1x G 3/4
		E	1 x gland G 3/4, TF16-11
		F	2 x gland G 3/4, TF16-11
		G	1 x gland G 1, TF22-15
		H	1 x thread NPT1
		K	1 x thread M25
		M	1 x gland G 1-1/4, TF28-20, 1x gland G 3/4, TF16-11
		Q	1 x thread NPT3/4
		R	2 x thread NPT3/4
		Y	Special version, TSP-no. to be spec.
<b>080</b>	<b>Installation Gauge:</b>	1	LT1100/LT1200/LT3100/LT3200 R:300mm low pressure LT version
		2	LT1400/LT1600/LT3400/LT3600 R:300mm high pressure LT version
		3	LTC2100 L:600mm
		4	LTC2230/LTC2240 R:600mm
		9	Special version, TSP-no. to be spec.



## 2.3 Scope of Delivery



### Caution!

It is extremely important to follow the instructions concerning the unpacking, transportation and storage of measuring instruments provided in the chapter "Incoming Acceptance, Transportation, Storage".

The scope of delivery consists of:

- Assembled Instrument

Accompanying Documentation:

- Operating Manual (this manual)
- Safety Instructions

## 2.4 Registered Trademarks

HART®

Registered trademark of HART Communication Foundation, Austin, USA



## 3 Installation

### 3.1 Incoming Acceptance, Transport, Storage

#### 3.1.1 Incoming Acceptance

Check the packing and contents for any signs of damage.

Check the shipment, and make sure that nothing is missing and that the items match your order.

#### 3.1.2 Transport



#### Caution!

- Follow the safety instructions and conditions of transportation for instruments in excess of 18kg (40 lbs.).
- Do not lift the measuring instrument by its terminal box during transportation.

#### 3.1.3 Storage

Pack the measuring instrument so that it is protected against impacts during storage and transportation.

The original packing material provides the optimum protection for this.

The allowed storage temperature is  $-20^{\circ}\text{C}$  to  $+60^{\circ}\text{C}$  ( $-4^{\circ}\text{F}$  to  $+140^{\circ}\text{F}$ )

## 3.2 Installation Conditions

### 3.2.1 Dimensions

#### Flame Proof Type

Alarm Output: 0, 2, 4, 6 points

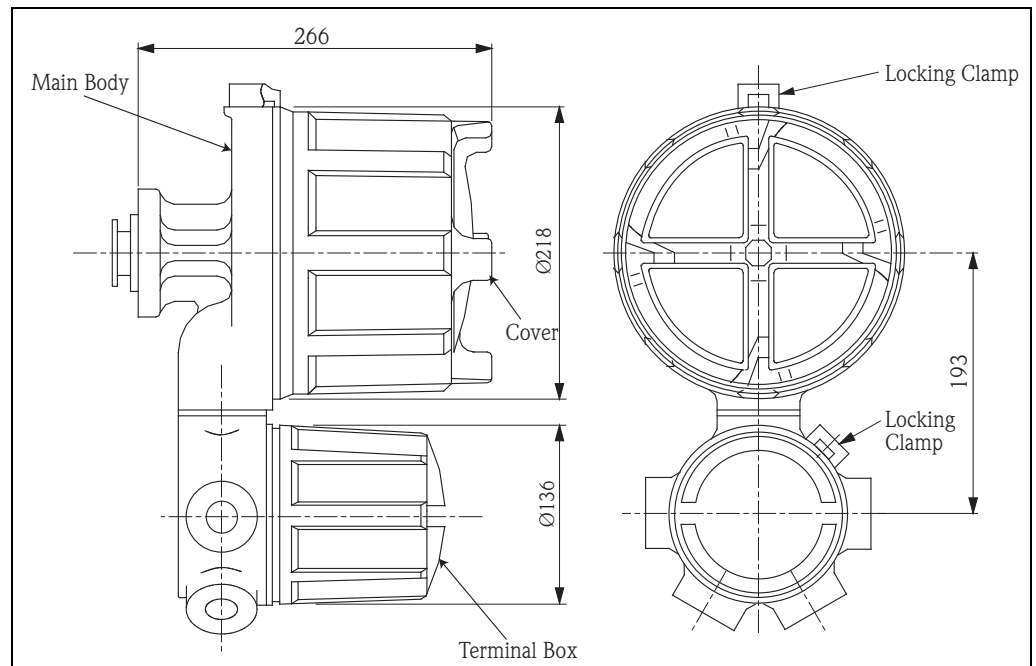

Figure 2: Dimension of Flame Proof Type

**Weather Proof**

**Alarm Output: 0, 2 Points, Cable Entry G 3/4, NPT 3/4**

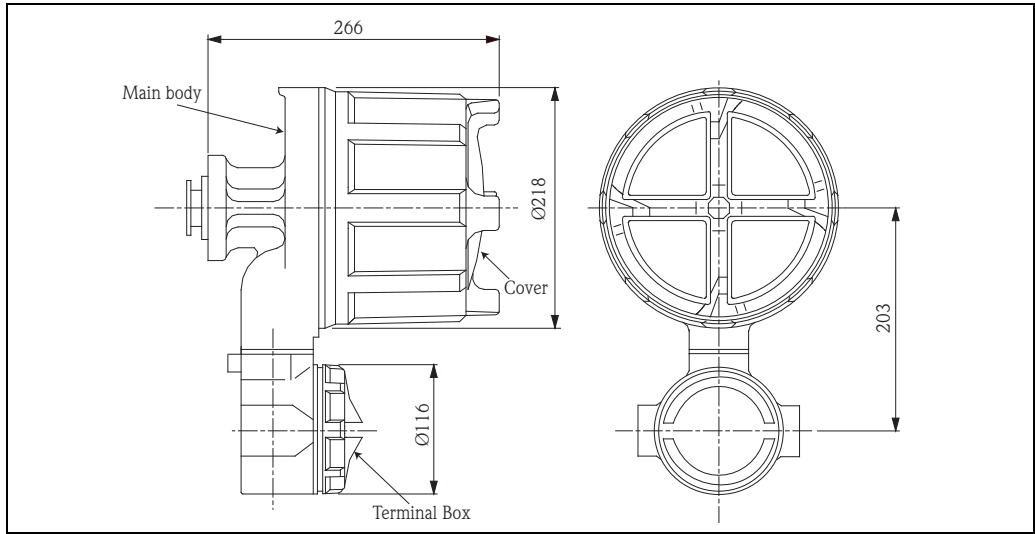

Figure 3: Dimension of Weather Proof 1

**Alarm Output: 0, 2, 4, 6 Points**

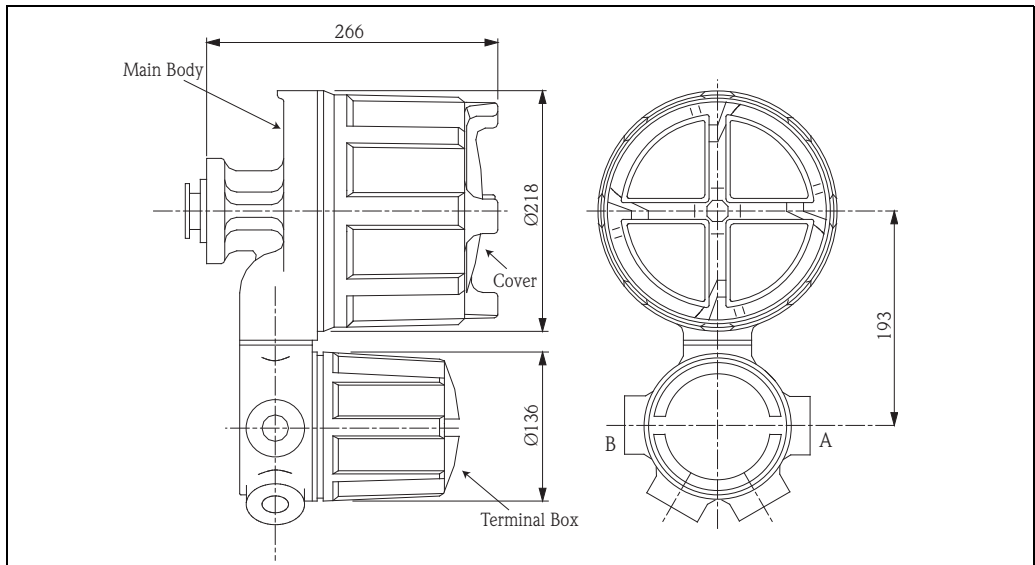

Figure 4: Dimension of Weather Proof 2

**Cable Entry**

070:Cable Entry	A	B	070:Cable Entry	A	B
A	Thread G 3/4		G	Gland G1 TF 22-15	
B	Thread G 3/4	Thread G 3/4	H	Thread NPT1	
C	Thread G 1-1/2		K	Thread M25	
D	Thread G 1-1/2	Thread G 3/4	M	Gland G1-1/4 TF28-20	Gland G 3/4 TF16-11
E	Gland G 3/4 TF16-11		Q	Thread NPT3/4	
F	Gland G 3/4 TF16-11	Gland G 3/4 TF16-11	R	Thread NPT 3/4	Thread NPT 3/4

### 3.3 Installation and Setting of Transmitter

Attach the stud bolt, nut, washer, and coupling to the level gauge to the level gauge and AT1 transmitter as shown in the diagram below.

#### Preparation of Installation

1. Remove the blind plate of the transmitter that is attached to back of the level gauge.
2. Screw the stud bolts onto the back of the level gauge, as shown in the diagram.
  - The side with the shorter screw is the level gauge side.
3. Insert the coupling into the drive shaft of the transmitter, and secure the coupling with the tooth lock washer and the nut.

This completes the installation procedure.

#### Setting Procedure of Multiple-alarm Point Model

1. Remove the cover of the transmitter.
2. Loosen the stopper screw at the alarm cam, set the red guideline onto the desired alarm point on the scale, and secure it with the stopper screw.
3. Repeat step 2 to set each cam.
4. When cam setting is completed, set the level on the standard scale by rotating the coupling to match the level setting on the level gauge. Then, close the cover and install it onto the level gauge.

This completes the setting procedure of multiple-alarm point model.

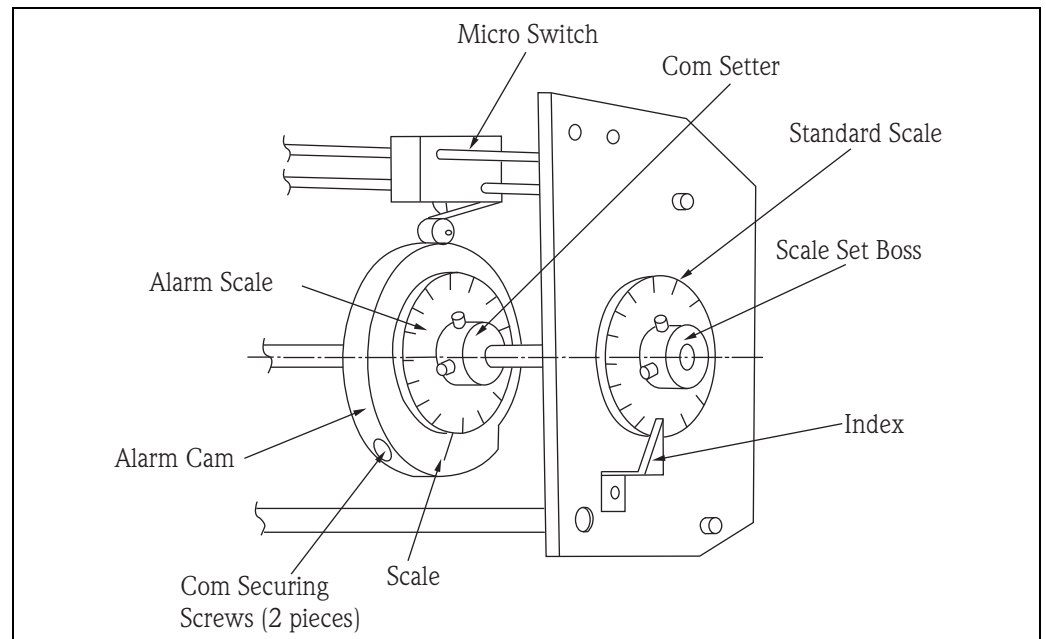

Figure 5: Installation of Multiple-alarm Point Model

### Installation Procedure of Non Equipped Model of Alarm Contact

1. Remove the cover of the transmitter if the transmitter is non-equipped alarm specification.
2. Rotate the coupling to adjust the set level of the potentiometer (or the alarm) to correspond to the set level of the level gauge, and then close the main body cover.
3. Mount the supplied O-ring on the transmitter and align the groove on the coupling with the coupling pin on the level gauge.
4. Secure the alarm contact to the level gauge with a washer and a nut.
  - If the groove on the coupling and the pin are not aligned, the mounting surface between the level gauge and the transmitter may have gap.

This completes the installation procedure of non equipped model of alarm contact.



#### Note!

The terminal box can be attached to the tank in any direction, however it is recommended to attach it sideways.

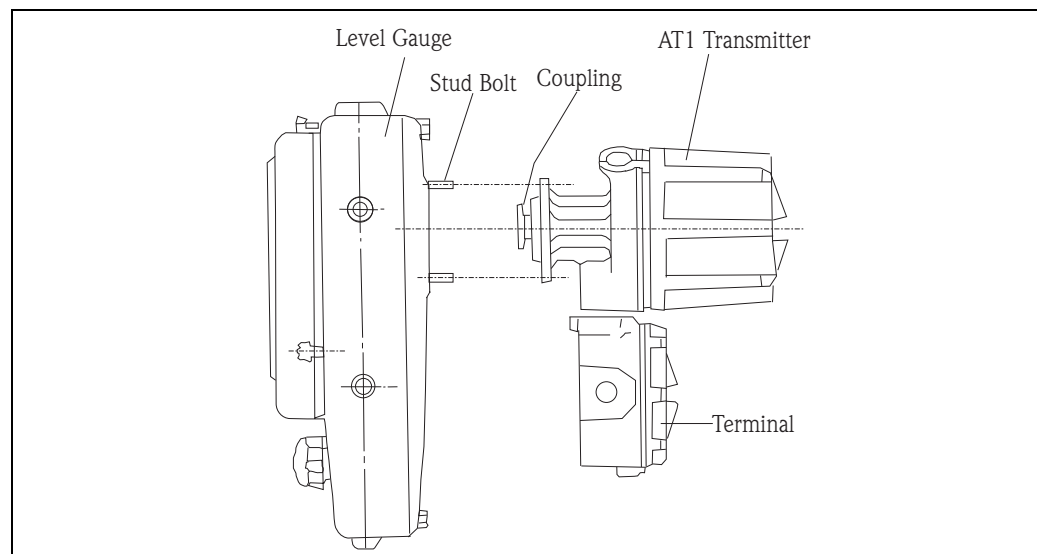

Figure 6: Installation of AT1 Transmitter



#### Note!

If there is a gap between the level gauge and the transmitter, do not push and forcibly install the coupling. Check the position of the coupling and re-install using the procedures above.

Forcibly installing the coupling may cause damage or malfunction of the drive shaft or the device.

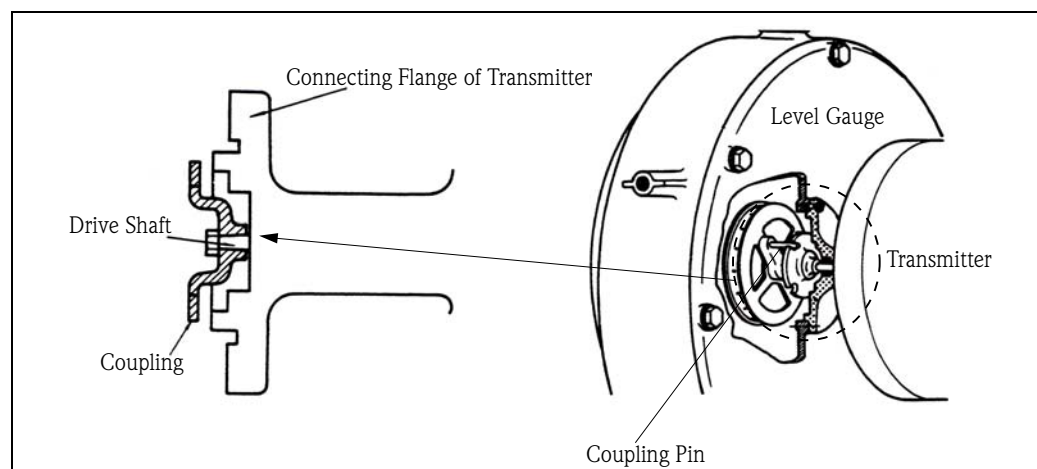

Figure 7: Couplings

**Installation at Low Pressure (LT11/12/31/32)**

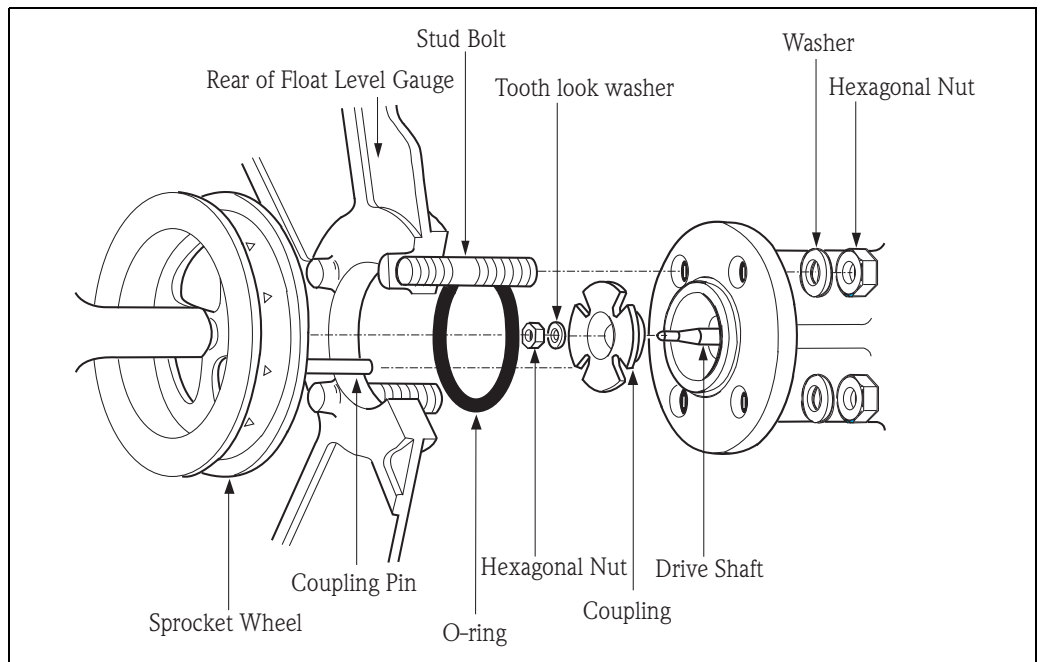

Figure 8: Installation for Low Pressure

**Installation at Medium and High Pressure (LT14/16/34/36)**

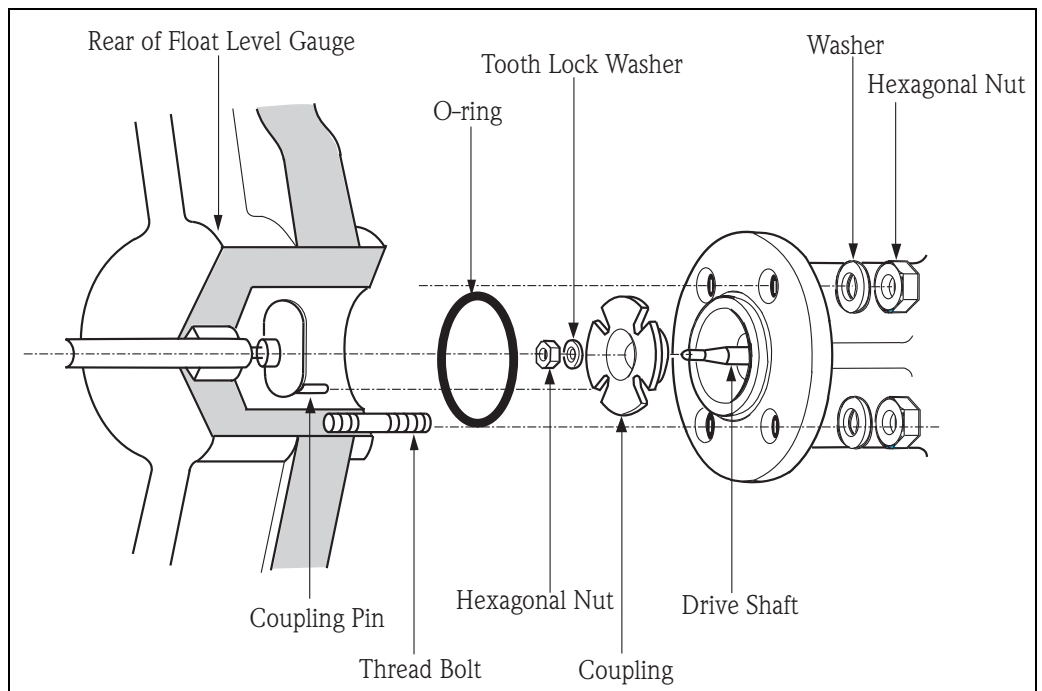

Figure 9: Installation for Medium and High Pressure

### 3.3.1 Installation of Transmitter to Float Tank Gauge

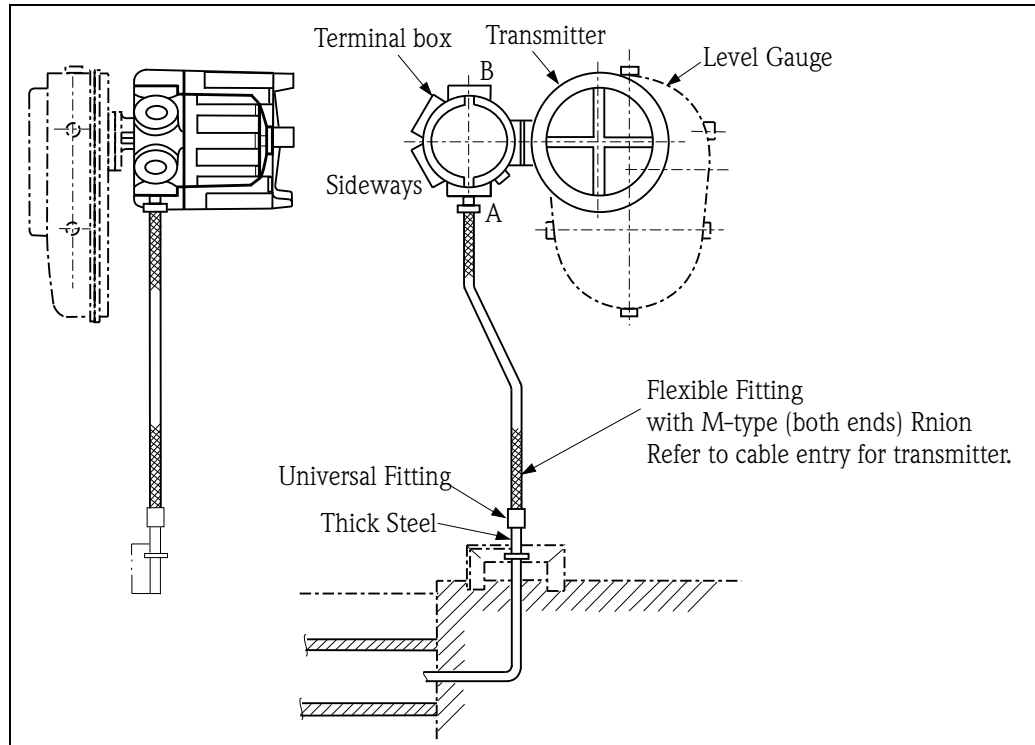

Figure 10: Transmitter and Tank Gauge



#### Caution!

When installing the transmitter with cable glands, ensure to use cable glands which are attached to the transmitter. Select an option for cable glands in the feature 070 of the order structure (refer to "2.2 Ordering Information").

## 4 Wiring

To maintain the transmitter and its accuracy, it is important to set the wiring and connection of the circuit to be within the accepted range. In AT1 analogue transmitter, there are several output signals. Be alert for the impedance that is caused by the circuit resistance as a result of electric output.

### 1. AC: 4 - 20mA or 10 - 50mA Output

(For alarm contact equipped model, refer to 5 also)

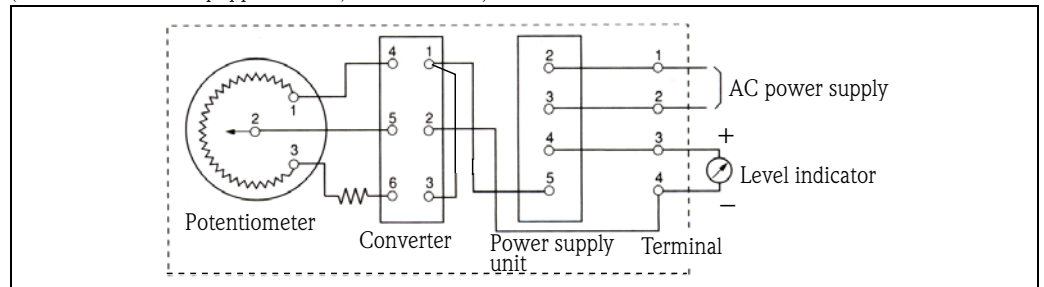

Figure 11: AC: 4-20mA or 10-50mA Output

### 2. AC: 0 - 1mA, 0 - 20mA, 0 - 10mV, 0 - 1V Output

(For alarm contact equipped model, refer to 5 also)

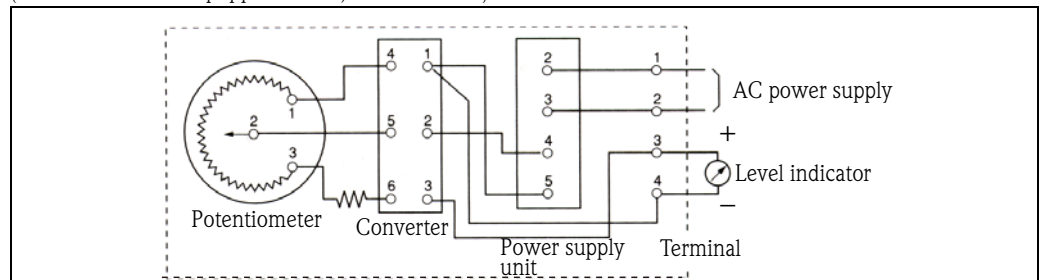

Figure 12: AC: 0-1mA, 0-20mA, 0-10mV, 0-1V Output

### 3. DC: 4 - 20mA or 10 - 50mA Output

(For alarm contact equipped model, refer to 5 also)

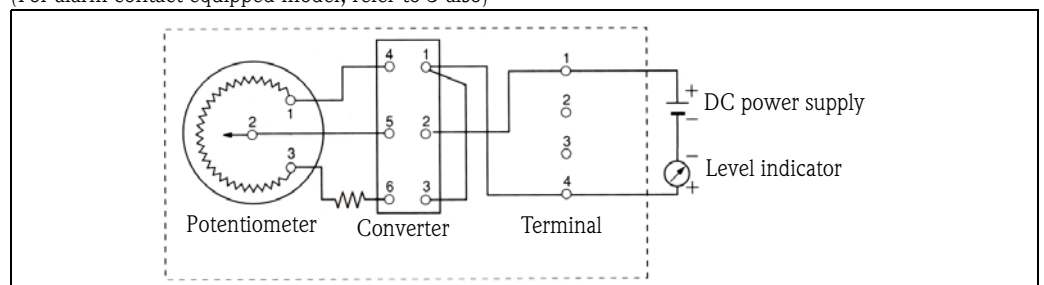

Figure 13: DC: 4-20mA or 10-50mA Output

### 4. DC: 0 - 1mA, 0 - 20mA, 0 - 10V, 0 - 1V Output

(For alarm contact equipped model, refer to 5 also)

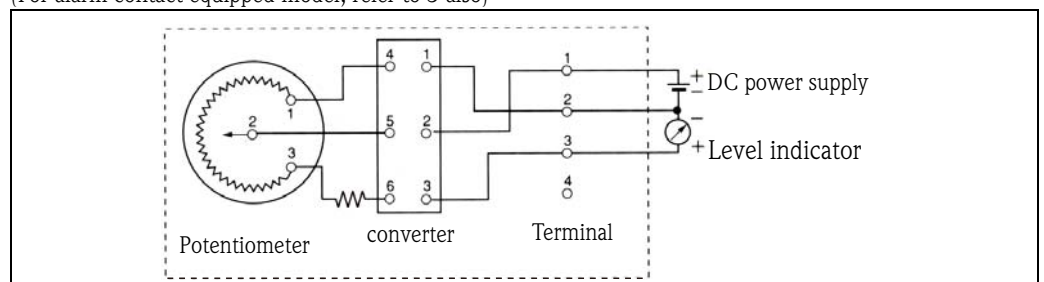

Figure 14: DC: 0-1mA, 0-20mA, 0-10V, 0-1V Output

**5. With Alarm Contacts**

In case of with contacts in 1, 2, 3, and 4, the following circuits are provided.

**A Contact (Normal Open)**

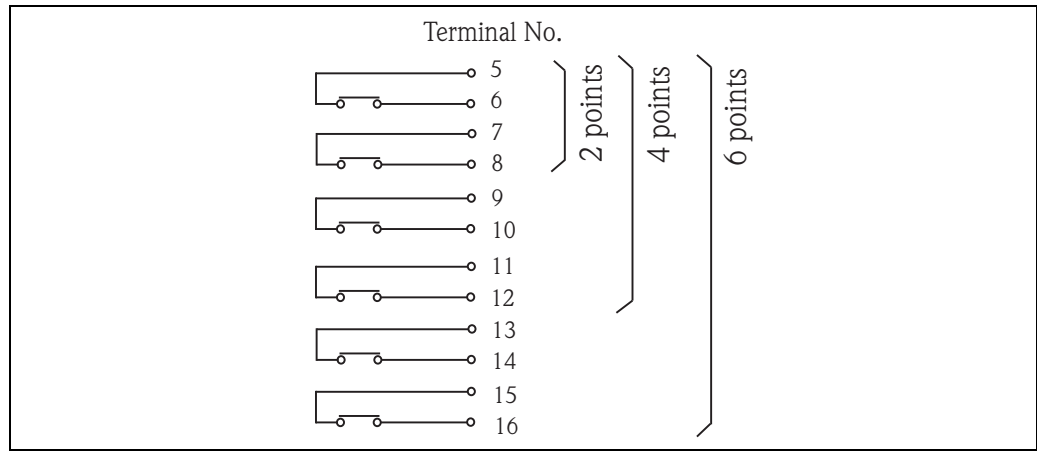

Figure 15: A Contact

**B Contact (Normal Close)**

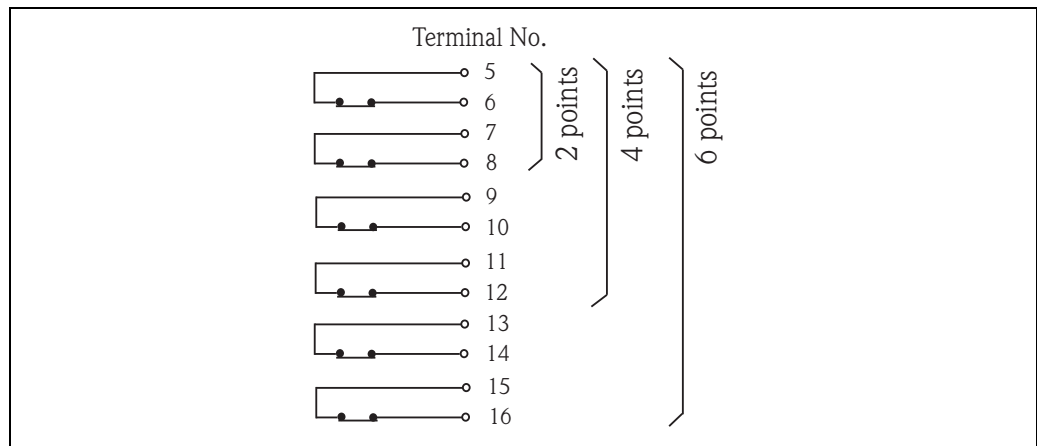

Figure 16: B Contact

**C Contact (Transfer Contact)**

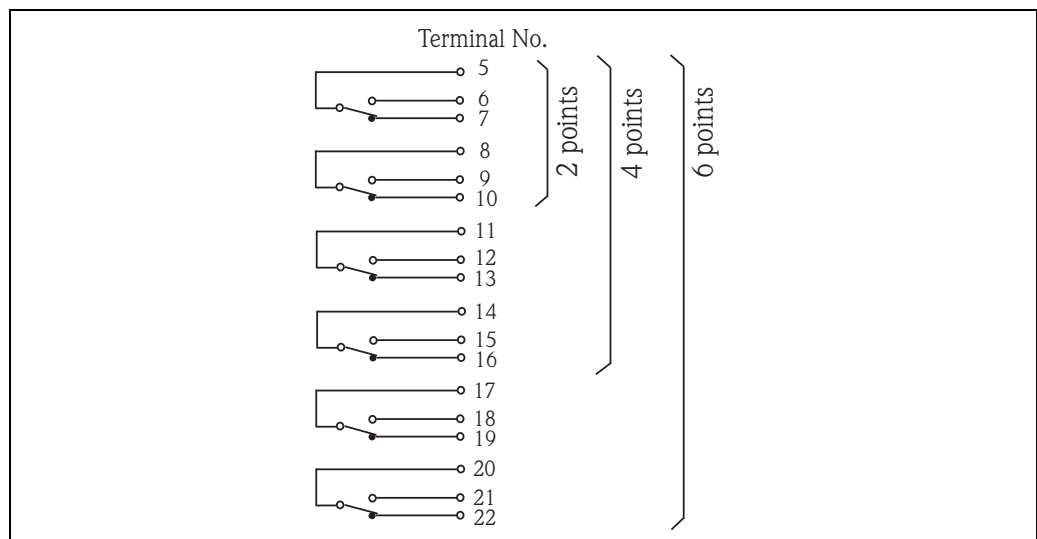

Figure 17: C Contact



## 5 Operation

### 5.1 Span Adjustment

The zero point cannot be changed, however the location of the 100% level can easily be changed.

When the level can be changed;

1. Remove the main body cover when the tank level reaches to the desired 100% level.
2. Set the level indicator to 100% using the span adjustment screw on the converter.
3. Close the main body cover

When the level cannot be changed;

1. Remove the transmitter from the level gauge, and remove the main body cover
2. Rotate the coupling to adjust the scale to the desired 100% level.
3. Set the level indicator to 100% by using the span adjustment screw on the converter.
4. Rotate the coupling again to align the scale of the transmitter with that of the level gauge.
5. Close the main body cover and install to the level gauge.

The allowable range of the span adjustment is from +0% to -20% of the maximum value of the scale of the transmitter.

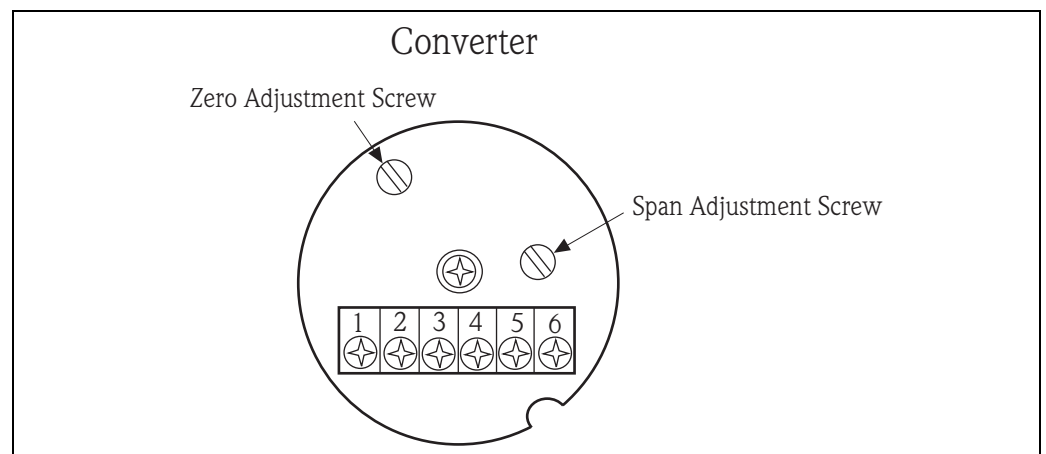

Figure 18: Span Adjustment

## 6 Maintenance

After the transmitter and receiver have been installed and adjusted, ensure to replace the cover of the transmitter.

Check AT1 transmitter periodically in accordance with the following maintenance procedures.

Checking Spots	Checking Procedures	Countermeasures
Converter	Check for a discrepancy between the level at the transmitter (after conversion) and the level at the tank gauge.	If there is any discrepancy, readjust the setting accordingly.
Alarm cam	Check for an alarm cam (switching point).	If the switching point shifts from the right place, readjust the point.
Alarm micro-switch	Check for a contact performance.	Replace the faulty-micro switch with a new one.
Wiring and connected terminal	Check for a disconnection or loose connection terminal.	

### Repairs

The Endress+Hauser repair policy is based on the fact that the measuring devices have a modular design and that customers are able to undertake repairs themselves. Spare parts are contained in corresponding kits along with their related replacement instructions. Endress+Hauser provides spare parts for repairs of AT1000 or AT1, which are located with their order numbers on later pages (refer to "7.1 Spare Parts"). Contact Endress+Hauser service representatives for further assistance regarding service and spare parts.

### Repairs to Ex-approved Devices

When performing repairs on Ex-approved devices, note the following:

- Repairs of Ex-approved devices may only be performed by trained personnel or by Endress+Hauser Service.
- Comply with the prevailing standards, national Ex-area regulations, safety instructions (XA) and other relevant rules.
- Only use original spare parts provided by Endress+Hauser.
- When ordering spare parts, note the device information on the nameplate. Replace parts only with parts that have the same device information.
- Perform repairs according to the instructions. When completing repairs, perform the specified routine test on the device.
- Only Endress+Hauser service representatives may convert a certified device into a different certified variant.
- Document all repair work and conversions.

# 7 Troubleshooting

## 7.1 Spare Parts

Spare parts are contained in kits. Spare parts for AT1000 or AT1 which can be ordered from Endress+Hauser are shown with their order numbers in the diagram below. Contact Endress+Hauser service representatives for further assistance.

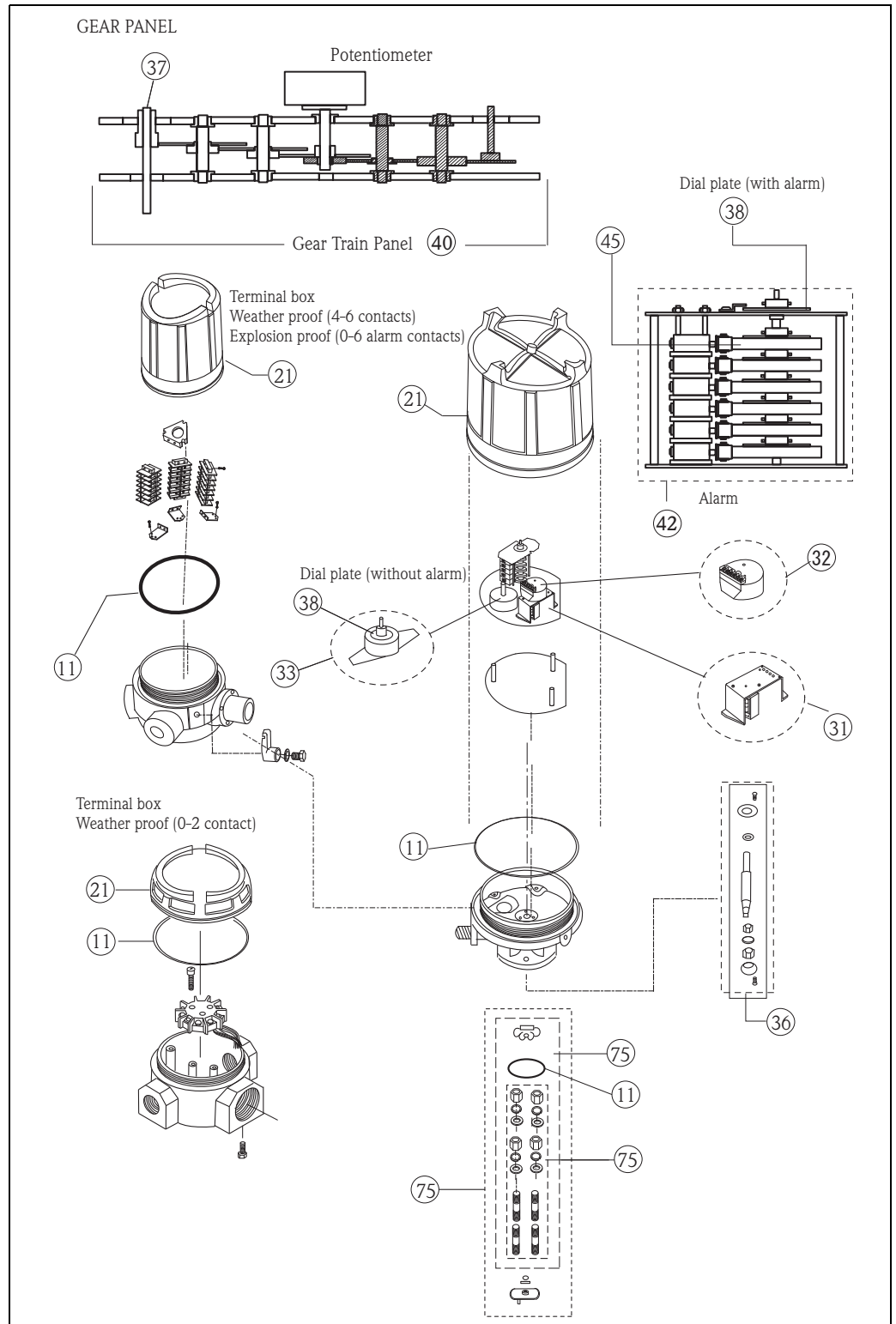

No.	Specification	No.	Specification
11 O-ring, packing		33 Electronic potentiometer	
017880-5025	O ring, Main body, NBR	017871-1202	Potentiometer, CPP45, LT, LTC2230/2240
017880-5026	O ring, Terminal box , small, NBR	56004470	Potentiometer, CPP45, LTC2110
017880-5027	O ring, El-compartment, large	35 Terminal	
017871-1231	O ring, LT/transmitter coupling	56004497	Stud, terminal, Round type, AT1
21 Cover		36 Main shaft	
017860-6323	Cover, terminal box, cover	017871-1210	main shaft assembly, AT1
017860-6326	Large-short cover, main body	37 Input gear	
017860-6324	Cover, terminal box, large	017871-1211	Gear, d=11mm
31 Electronic power module		017871-1212	Gear, d=15mm
01781-1201	Power unit R/I AC100V	45 Alarm cam	
56004475	Power unit R/I AC110V	017871-1220	Alarm cam
56004479	Power unit R/I AC200V	75 Accessory	
56004476	Power unit R/I AC220V	70106501	Stud bolt M10x40L, (spr. Washer+Washer) 4 sets
32 Electronic R/I converter		017871-1233	Coupling, transmitter, LT11/LT12
017871-1207	converter R/I DC power	017871-1232	Coupling, transmitter, LT14/LT16
56004478	converter R/I AC power		

38 Dial Plate

XPNO001 Dial Plate

<b>030</b>	<b>Alarm Output:</b>
0	Not used
2	2 - point
4	4 - point
6	6 - point
<b>080</b>	<b>Installation Gauge:</b>
1	LT1100/LT1200/LT3100/LT3200 R:300mm low pressure LT version
2	LT1400/LT1600/LT3400/LT3600 R:300mm high pressure LT version
3	LTC2100 L:600mm
4	LTC2230/LTC2240 R:600mm
<b>090</b>	<b>Measuring Range:</b>
A	1.5m
1	2.5m
C	3m
D	3.5m
E	4m
2	5m
F	6m
G	8m
3	10m
H	12m
J	14m
4	16m
5	20m
K	25m
6	30m

**AT1-** Complete product designation

40 Gear Train Panel  
 XPN0002 Gear Pannel Assembly

<b>030</b>	<b>Alarm Output:</b>
	0 Not used
	2 2 - point
	4 4 - point
	6 6 - point
<b>080</b>	<b>Installation Gauge:</b>
	1 LT1100/LT1200/LT3100/LT3200 R:300 low pressure LT version
	2 LT1400/LT1600/LT3400/LT3600 R:300 high pressure LT version
	3 LTC2100 L:600mm
	4 LTC2230/LTC2240 R:600mm
<b>090</b>	<b>Measuring Range</b>
	A 1.5m
	1 2.5m
	C 3m
	D 3.5m
	E 4m
	2 5m
	F 6m
	G 8m
	3 10m
	H 12m
	J 14m
	4 16m
	5 20m
	K 25m
	6 30m

**AT1-** Complete product designation

42 Alarm Output Assembly (Cam & Micro Switch)  
 XPN0003 Alarm Assembly

<b>030</b>	<b>Alarm Output:</b>
	2 2 - point
	4 4 - point
	6 6 - point
<b>080</b>	<b>Installation Gauge</b>
	1 LT1100/LT1200/LT3100/LT3200 R:300mm low pressure LTversion
	2 LT1400/LT1600/LT3400/LT3600 R:300mm high pressure LTversion
	3 LTC2100 L:600?
	4 LTC2230/LTC2240 R:600?
<b>090</b>	<b>Measuring Range:</b>
	A 1.5m
	1 2.5m
	C 3m
	D 3.5m
	E 4m
	2 5m
	F 6m
	G 8m
	3 10m
	H 12m
	J 14m
	4 16m
	5 20m
	K 25m
	6 30m

**AT1-** Complete product designation

## 7.2 Troubleshooting

Error condition	Cause	Countermeasure
The display shows no change at all.	<ol style="list-style-type: none"> <li>1. Gear set screw is loose.</li> <li>2. Broken or disconnection of wires at the terminal position</li> </ol>	<ol style="list-style-type: none"> <li>1. Tighten the set screw, or replace if the press fitting faulty.</li> <li>2. Check the wiring and the terminal connection and firmly connect the wires at the end.</li> </ol>
Display level is too high.	<ol style="list-style-type: none"> <li>1. Gear set screw is loose.</li> <li>2. Increase in resistance caused by friction in the potentiometer</li> </ol>	<ol style="list-style-type: none"> <li>1. Tighten the setscrew and reset the level.</li> <li>2. Replace the potentiometer.</li> </ol>
Display level is too low.	<ol style="list-style-type: none"> <li>1. Gear set screw is loose.</li> </ol>	<ol style="list-style-type: none"> <li>1. Tighten the set screw and reset the level.</li> </ol>
Alarm does not work or return.	<ol style="list-style-type: none"> <li>1. Set screw of the alarm cam or the scale is loose.</li> <li>2. Micro switch is not working properly.</li> <li>3. Wires are broken or short-circuited.</li> </ol>	<ol style="list-style-type: none"> <li>1. Tighten the setscrew and reset the level.</li> <li>2. Replace the micro switch.</li> <li>3. Redo the wiring connection.</li> </ol>

## 7.3 Return

The following procedure must be performed before returning AT1000 or AT1 transmitter to Endress+Hauser e.g. for repair or calibration.

- Remove all residue. Pay special attention to the gasket grooves and crevices where fluid may be present. This is especially important if the fluid is corrosive, poisonous, carcinogenic, radioactive, or otherwise hazardous.
- Always enclose a duly completed "Declaration of Hazardous Material and De-contamination" form (a copy of the "Declaration of Hazardous Material and De-contamination" is included at the end of this operating manual). Only then can Endress+Hauser transport, examine, and repair a returned device.
- Enclose special handling instructions if necessary, for example a safety data sheet as per EN 91/155/EEC.

Additionally specify:

- An exact description of the application
- The chemical and physical characteristics of the instrument
- A short description of the error that occurred (specify the error code where possible)
- Operating time of the device

## 7.4 Disposal

In case of disposal, separate the various components according to their materials.

## 7.5 Contact Addresses of Endress+Hauser

The addresses of Endress+Hauser are given on the back cover of this operating manual. If you have any questions, do not hesitate to contact Endress+Hauser representative.

## 8 Technical Data

Output	4 - 20mA, 10 - 50mA, 0 - 1mA, 0 - 20mA, 0 - 10mV, 0 - 1V	
Accuracy	Analog Output	4 - 20mA, 10 - 50mA Output: Within $\pm 0.5\%$ 0 - 20mA, 0 - 10mV, 0 - 1V Output: Within $\pm 0.7\%$ 0 - 1mA Output: within $\pm 1.5\%$
	Alarm Contact Output	$\pm 0.5\%$ (for full span)
Power Supply	24VDC (20 - 40VDC valid) AC100V/110V/220V/220V $\pm 10\%$ , 50/60Hz	
Power Consumption	Approximately 5VA	
Ambient Temperature	Weather proof type: -20 to +60 °C Flameproof type: -10 to +40 °C (Accuracy coverage: 0 to 40 °C)	
Storage Temperature	-20 to +60 °C	
Measuring Range	0 - 1.5m, 2.5m, 3m, 3.5m, 4m, 5m, 6m, 8m, 10m, 12m, 14m, 16m, 20m, 25m, 30m	
Hysteresis	Within 2% of measuring range	
Cable Entry	Flameproof with cable gland (B): G3/4 TF16-11, G1 TF22-15, G1-1/4 TF28-20 Flameproof (E): G3/4 , G1-1/2 Weather proof (W): G3/4 , G1-1/2, NPT3/4, NPT1, M25	
Transmission Line (per one contact)	DC: two or three lines AC: four lines	
Alarm Contacts	2, 4, 6 points, Micro switch (SPDT) Select any of the following contact: A contact (normal open) B contact (normal close) C contact (transfer)	
Contact Rating	TIIS Ex d rating: 250V 4.2A, 1050VA, 180W Allowable Alarm 2 points (A, B, C contact) 220VAC 2.8A, 125VDC 0.5A contact rating Alarm 4 points (A, B contact) 220VAC 2.8A, 125VDC 0.5A Alarm 4 points (C contact) 220VAC 2.2A, 125VDC 0.5A Alarm 6 points (A, B, C contact) 220VAC 2.2A, 125VDC 0.5A	
Protection	Weather proof: IP65 Flame proof: d2G4	
Color	Silver	
Weight	Weather proof: approximately 7kg Flame proof: approximately 13kg	

### Load Impedance (maximum)

	Voltage Current	DC20V	DC24V	DC40V	AC100V AC110V AC200V AC220V
		Current Output (Max. Impedance)	4 - 20mA	200 $\Omega$	400 $\Omega$
	10 - 50mA	80 $\Omega$	160 $\Omega$	440 $\Omega$	250 $\Omega$
	0 - 1mA	18k $\Omega$	22k $\Omega$	38k $\Omega$	25k $\Omega$
	0 - 20mA	900 $\Omega$	1100 $\Omega$	1900 $\Omega$	1330 $\Omega$
Voltage Output (mm. Impedance)	0 - 10mV	500 $\Omega$ or more			
	0 - 1V	30k $\Omega$ or more			

## Declaration of Hazardous Material and De-Contamination Erklärung zur Kontamination und Reinigung

**RA No.**

Please reference the Return Authorization Number (RA#), obtained from Endress+Hauser, on all paperwork and mark the RA# clearly on the outside of the box. If this procedure is not followed, it may result in the refusal of the package at our facility.  
Bitte geben Sie die von E+H mitgeteilte Rücklieferungsnummer (RA#) auf allen Lieferpapieren an und vermerken Sie diese auch außen auf der Verpackung. Nichtbeachtung dieser Anweisung führt zur Ablehnung ihrer Lieferung.

Because of legal regulations and for the safety of our employees and operating equipment, we need the "Declaration of Hazardous Material and De-Contamination", with your signature, before your order can be handled. Please make absolutely sure to attach it to the outside of the packaging.

Aufgrund der gesetzlichen Vorschriften und zum Schutz unserer Mitarbeiter und Betriebseinrichtungen, benötigen wir die unterschriebene "Erklärung zur Kontamination und Reinigung", bevor Ihr Auftrag bearbeitet werden kann. Bringen Sie diese unbedingt außen an der Verpackung an.

Type of instrument / sensor  
Geräte-/Sensortyp \_\_\_\_\_

Serial number  
Seriennummer \_\_\_\_\_

Used as SIL device in a Safety Instrumented System / Einsatz als SIL Gerät in Schutzeinrichtungen

Process data/Prozessdaten  
Temperature / Temperatur \_\_\_\_\_ [°F] \_\_\_\_\_ [°C] Pressure / Druck \_\_\_\_\_ [psi] \_\_\_\_\_ [Pa]  
Conductivity / Leitfähigkeit \_\_\_\_\_ [µS/cm] Viscosity / Viskosität \_\_\_\_\_ [cp] \_\_\_\_\_ [mm<sup>2</sup>/s]

Medium and warnings  
Warnhinweise zum Medium



	Medium /concentration Medium /Konzentration	Identification CAS No.	flammable entzündlich	toxic giftig	corrosive ätzend	harmful/ irritant gesundheitsschädlich/ reizend	other * sonstiges*	harmless unbedenklich
Process medium Medium im Prozess								
Medium for process cleaning Medium zur Prozessreinigung								
Returned part cleaned with Medium zur Endreinigung								

\* explosive; oxidising; dangerous for the environment; biological risk; radioactive

\* explosive; brandfördernd; umweltgefährlich; biogefährlich; radioaktiv

Please tick should one of the above be applicable, include safety data sheet and, if necessary, special handling instructions.  
Zutreffendes ankreuzen; trifft einer der Warnhinweise zu, Sicherheitsdatenblatt und ggf. spezielle Handhabungsvorschriften beilegen.

Description of failure / Fehlerbeschreibung \_\_\_\_\_  
\_\_\_\_\_  
\_\_\_\_\_

Company data / Angaben zum Absender

Company /Firma _____	Phone number of contact person /Telefon-Nr. Ansprechpartner: _____
Address / Adresse _____	Fax / E-Mail _____
_____	Your order No. / Ihre Auftragsnr. _____

"We hereby certify that this declaration is filled out truthfully and completely to the best of our knowledge. We further certify that the returned parts have been carefully cleaned. To the best of our knowledge they are free of any residues in dangerous quantities."

"Wir bestätigen, die vorliegende Erklärung nach unserem besten Wissen wahrheitsgetreu und vollständig ausgefüllt zu haben. Wir bestätigen weiter, dass die zurückgesandten Teile sorgfältig gereinigt wurden und nach unserem besten Wissen frei von Rückständen in gefahrbringender Menge sind."

\_\_\_\_\_  
(place, date / Ort, Datum)

\_\_\_\_\_  
Name, dept./Abt. (please print /bitte Druckschrift)

\_\_\_\_\_  
Signature / Unterschrift



---

Endress + Hauser Japan Co., Ltd.  
Product Center Yamanashi  
862-1 Mitsukunugi Sakaigawa-cho  
Fuefuki-shi Yamanashi,  
406-0846 Japan

Phone: ++81 55 266 4964  
Fax: ++81 55 266 4969

Endress + Hauser   
People for Process Automation